

# MAC 550 Profile

user manual



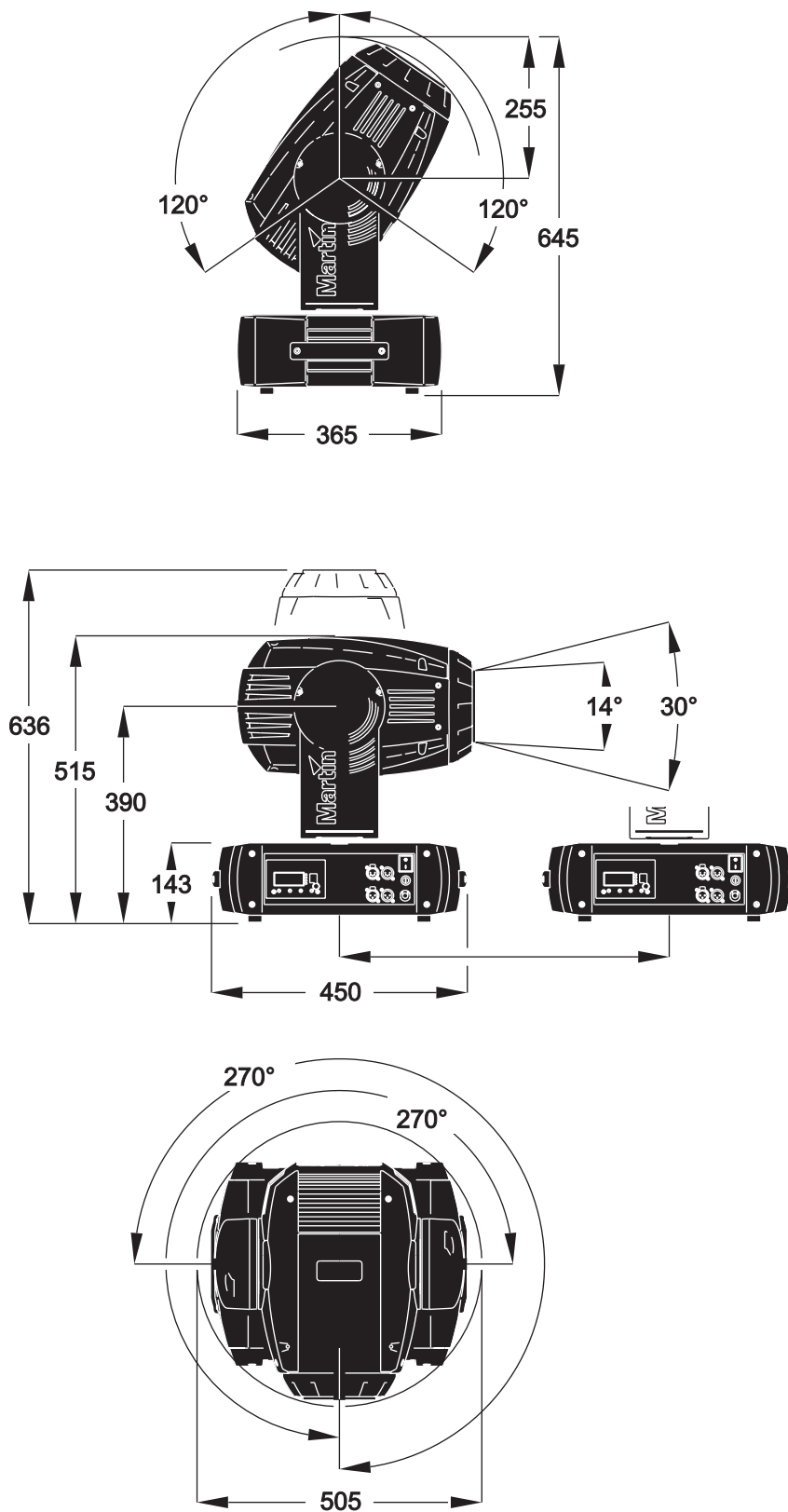

Figure 1: Dimensions in mm

# Contents

INTRODUCTION .....	5
Safety information .....	5
Unpacking .....	6
Initial set-up .....	6
LAMP .....	7
About the discharge lamp .....	7
Lamp replacement .....	7
AC POWER .....	9
Fuses .....	9
Power supply adjustment .....	9
Power connection .....	9
DATA .....	10
Tips for reliable data transmission .....	10
RIGGING .....	11
CONTROL PANEL .....	12
Menu navigation .....	12
DMX address and protocol .....	12
Tailoring performance .....	12
Readouts .....	13
Manual control .....	14
Service utilities .....	14
EFFECTS .....	15
Lamp power .....	15
Fixture reset .....	15
Dimming and strobe .....	15
Color .....	16
Rotating gobos .....	16
Static gobos .....	16
Gobo macros .....	16
Gobo animation .....	16
Prism and iris .....	16
Focus and zoom .....	16
Pan and tilt .....	17
Speed channels .....	17
OPTICAL CONFIGURATION .....	18
Color wheels .....	18
Gobos .....	19
Animation wheel .....	21
Prism .....	22
ROUTINE MAINTENANCE .....	23
Tilt lock .....	23
Disassembly .....	23
Cleaning .....	25
Lubrication .....	26
Lampholder replacement .....	26
Software installation .....	26
DMX PROTOCOL .....	28
CONTROL MENU .....	33
ADJUSTMENT SUBMENU .....	37
CONTROL MENU SHORTCUTS .....	38
DISPLAY MESSAGES .....	39
TROUBLESHOOTING .....	40
CIRCUIT BOARD CONNECTIONS .....	41
MAC 550 PROFILE SPECIFICATIONS .....	42

## Notes

# INTRODUCTION

Thank you for selecting the Martin MAC 550 Profile. This 400 watt moving-head spotlight provides a full-range mechanical dimmer/shutter, 16 color filters on two overlapping wheels, six rotating gobos with 16-bit position indexing, nine static gobos, interchangeable gobo animation wheel, three-facet rotating prism, iris, variable focus and zoom, 540° of pan, 246° of tilt, and an electronic “flicker-free” ballast.

For the latest updates of product documentation and software, please visit the support area of the Martin website at <http://www.martin.com>

## Safety information

**Warning!** *This product is for professional use only. It is not for household use.*

This product presents risks of lethal or severe injury due to fire and heat, electric shock, ultraviolet radiation, lamp explosion, and falls. **Read this manual** before powering or installing the fixture, follow the safety precautions listed below and observe all warnings in this manual and printed on the fixture. If you have questions about how to operate the fixture safely, please contact your Martin dealer or call the Martin 24-hour service hot line at +45 70 200 201.

### Protection from electric shock

- Disconnect the fixture from AC power before removing or installing the lamp, fuses, or any part, and when not in use.
- Always ground (earth) the fixture electrically.
- Use only a source of AC power that complies with local building and electrical codes and has both overload and ground-fault protection.
- Do not expose the fixture to rain or moisture.
- Refer any service operation not described in this manual to a qualified technician.

### Protection from UV radiation and lamp explosion

- Never operate the fixture with missing or damaged lenses and/or covers.
- When replacing the lamp, allow the fixture to cool for at least 30 minutes before opening the fixture or removing the lamp. Protect your hands and eyes with gloves and safety glasses.
- Do not stare directly into the light. Never look at an exposed lamp while it is lit.
- Replace the lamp if it becomes defective or worn out, or before usage exceeds the maximum service life.

### Protection from burns and fire

- Never attempt to bypass the thermostatic switch or fuses. Always replace defective fuses with ones of the specified type and rating.
- Keep all combustible materials (for example fabric, wood, paper) at least 0.5 meters (20 inches) away from the fixture. Keep flammable materials well away from the fixture.
- Do not illuminate surfaces within 1.0 meter (39 inches) of the fixture.
- Provide a minimum clearance of 0.1 meters (4 inches) around fans and air vents.
- Never place filters or other materials over the lens.
- The exterior of the fixture can get very hot. Allow the fixture to cool for at least 5 minutes before handling.
- Do not modify the fixture or install other than genuine Martin parts.
- Do not operate the fixture if the ambient temperature ( $T_a$ ) exceeds 40° C (104° F).

### Protection from injury due to falls

- When suspending the fixture, verify that the structure can hold at least 10 times the weight of all installed devices.
- Verify that all external covers and rigging hardware are securely fastened and use an approved means of secondary attachment such as a safety cable.
- Block access below the work area whenever installing or removing the fixture.

## Unpacking

The MAC 550 Profile is packaged in either a cardboard box or a two-unit flight case that is specifically designed to protect the product during shipment. The following items are included:

- OSRAM HTI 400/D3 lamp (installed)
- this user manual
- a 6.3 A fuse (installed) for use with 200 - 240 V power
- a 10 A fuse for use with 100-120 V power
- 2 clamp attachment brackets

## Initial set-up

Before applying power to the fixture,

- carefully review the safety information on page 5,
- verify that the MAC 550 Profile is configured for local AC power as described on page 9,
- install a plug on the power cable as described on page 9, and
- unlock the tilt lock as described on page 23.

When powered up, check lamp alignment as described on page 8.

# LAMP

## About the discharge lamp

The MAC 550 Profile is designed to use a double-ended 400 W discharge lamp. Two lamps are approved: the OSRAM HTI 400 W/D3 and the Philips MSR 400 SA/DE Gold. Both lamps have a color temperature of 7500K. The Osram lamp has an average service life of 1000 hours and the Philips lamp 750 hours. Both lamps are capable of hot restrike.

**Warning!** *Use only approved lamps. Installing any other lamp may create a safety hazard or damage the fixture! Discharge lamps can explode. Always wear safety glasses and gloves when replacing or servicing lamps.*

To reduce the risk of explosion, replace the lamp when it reaches the limit of its average service life. To read lamp hours from the control panel, please refer to “Readouts” on page 13. Replace the lamp immediately if it is in any way defective.

The lampholder must also be replaced at regular intervals (see “Lampholder replacement” on page 26).

For maximum service life, avoid turning off the lamp before it has warmed up for at least 5 minutes.

## Lamp replacement

**Important!** *Do not touch the quartz bulb with bare fingers.*

Replacement lamps are available from your Martin dealer.

The clear quartz bulb must be clean and free of any oils from your fingers. Clean the lamp with an alcohol wipe and polish it with a dry cloth, particularly if you accidentally touch the bulb.

### To replace the lamp

1. Disconnect the fixture from power and allow it to cool for at least 30 minutes or until the lamp access plate is cool enough to touch. Lock the head right-side up.
2. Release the 4 quarter-turn fasteners marked with arrows on the lamp access plate, as shown in Figure 1. Pull the lamp assembly straight back as far as it goes and let it rest in place.
3. Push down the retention spring on the right end of the socket and push out the pin. You can use a screwdriver to pry the lamp out of the socket as shown in Figure 2. Remove the lamp.

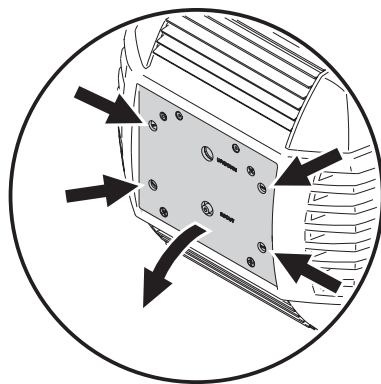

Figure 1: Lamp access

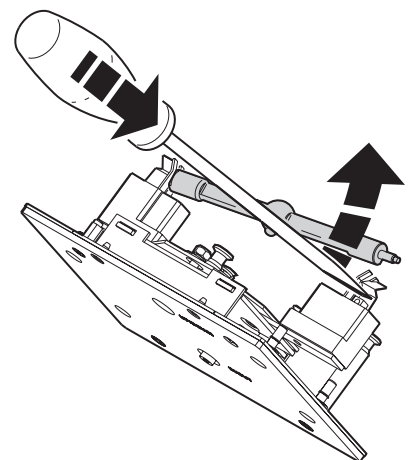

Figure 2: Lamp removal

4. Inspect the lampholder. If any discoloration or pitting is visible, replace the lampholder (see “Lampholder replacement” on page 26).

- With the nipple on the replacement lamp facing towards the back as shown in Figure 3, insert the left pin into the socket. Push down on the right-hand spring and snap the pin into place.

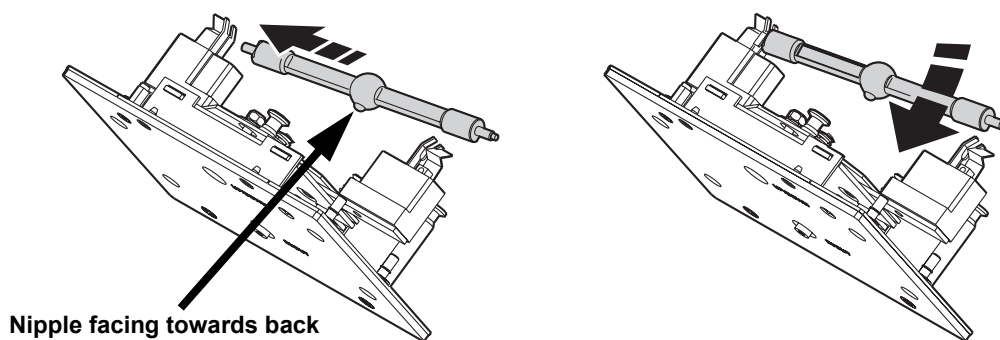

Figure 3: Lamp insertion

- Make sure that the terminals on the lamp sit below the V-section in the lampholder clips and not in the V-section itself, as shown in Figure 4.

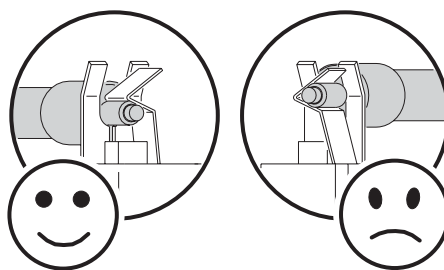

Figure 4: Lamp terminals

- Lift the lamp assembly so that lamp is level with the center of the reflector. Push the assembly straight in until it seats, making sure the lamp passes through the reflector opening.
- Push and turn the 4 fasteners a quarter turn or so clockwise to close the lamp access panel.
- After installing a new lamp, reset the lamp hour and lamp strike counters. See “Time” on page 13.

## To align the lamp

**Important!** *Align the lamp carefully. An excessive hot-spot will damage optical components.*

- Switch on the MAC 550 Profile and allow it to reset. Using either a controller or the control module, turn on the lamp and project an open white beam on a flat surface.
- Center the hot spot vertically using the top Allen-head adjustment screw in the center of the rear plate. (See Figure 5.) If there is significant hot spot, turn the bottom adjustment screw counterclockwise until the light is evenly distributed. If the light is brighter around the edge than it is in the center, or if light output is low, turn the bottom adjustment screw clockwise until the light is bright and evenly distributed.

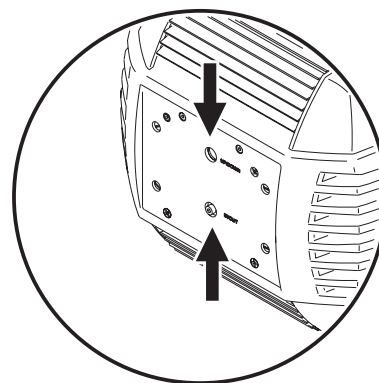

Figure 5: Lamp adjustment screws

# AC POWER

**WARNING!** For protection from electric shock, the fixture must be grounded (earthed). The AC power distribution system must be fitted with a fuse or circuit breaker and ground-fault protection.

Verify the fixture's power supply setting before applying power.

## Fuses

The MAC 550 Profile is supplied with two main fuses:

- a 6.3 A fuse (installed) for use with 200-240 Volts AC power.
- a 10 A fuse (packed with user manual) for use with 100-120 Volts AC power.

Install the appropriate fuse in the fuseholder beneath the power switch.

## Power supply adjustment

The MAC 550 Profile can operate on 100-120 or 200-240 VAC nominal power at 50/60 Hz. The voltage selection switch is set at the factory for 200-240 V. For use with 100-120 V power, the fixture must be reconfigured as follows.

### To configure the power supply

1. Disconnect the fixture from AC power.
2. Remove the metal top cover from the front of the base (front is indicated by an arrow on the base).
3. Locate the voltage selection switch. For operation on 200-240 V power, move the switch to the "230V" setting. For operation on 100-120 V power, move the switch to the "115V" setting. The MAC 550 Profile adapts automatically to 50 or 60 Hz.
4. Replace the base cover.
5. Remove the main fuse holder, which is located beneath the power switch. For operation on 200-240 V power, install the 6.3 A fuse. For operation on 100-120 V power, install the 10 A fuse.

## Power connection

**Important!** Connect the MAC 550 Profile directly to AC power. Do not connect it to a dimmer system; doing so may damage the fixture.

You may need to install a plug that fits your supply on the power cable. A 3-prong grounding-type plug must be installed following the manufacturer's instructions. The table shows some possible pin identification schemes. If the pins are not clearly identified, or if you have any doubts about proper installation, consult a qualified electrician.

To apply power, first verify that the head is unlocked and then set the power switch on the base to the "I" position.

Wire Color	Pin	Symbol	Screw (US)
brown	live	L	yellow or brass
blue	neutral	N	silver
yellow/green	ground		green

Table 1: Power plug connections

# DATA

***Important! Never connect more than 1 data input and 1 data output.***

The MAC 550 Profile has both 3-pin and 5-pin XLR sockets for DMX input and output. The pin-out on all sockets is pin 1 to shield, pin 2 to cold (-), and pin 3 to hot (+). There is no connection to pins 4 and 5.

The sockets are wired in parallel: both inputs connect to both outputs. *For reliable data transmission and to avoid damage to the fixture, never use more than one input and one output!*

## Tips for reliable data transmission

- Use shielded twisted-pair cable designed for RS-485 devices: standard microphone cable cannot transmit control data reliably over long runs. 24 AWG cable is suitable for runs up to 300 meters (1000 ft). Heavier gauge cable and/or an amplifier is recommended for longer runs.
- Never use both outputs to split the link. To split the serial link into branches use a splitter such as the Martin 4-Channel Opto-Isolated RS-485 Splitter/Amplifier.
- Do not overload the link. Up to 32 devices may be connected on a serial link.
- Terminate the link by installing a termination plug in the output socket of the last fixture. The termination plug, which is a male XLR plug with a 120 Ohm, 0.25 Watt resistor soldered between pins 2 and 3, “soaks up” the control signal so it does not reflect and cause interference. If a splitter is used, terminate each branch of the link.
- Martin fixtures introduced before 1997 have reversed polarity data sockets (pin 2 hot and pin 3 cold). The socket polarity is labelled. *Use a phase-reversing cable between the MAC 550 Profile and any Martin device with reversed polarity.*

## To connect the data link

1. Connect the DMX data output from the controller to the MAC 550 Profile’s 3-pin or 5-pin input (male) socket.
2. Using the sockets that match your data cable, connect the output of the fixture closest to the controller to the input of the next fixture.
3. Insert a male 120  $\Omega$  XLR termination plug in the 3-pin or 5-pin output of the last fixture on the link.

# RIGGING

The MAC 550 Profile can be placed on stage or clamped to truss in any orientation. The mounting points allow the clamp brackets to be fastened parallel or perpendicular to the front as shown Figure 6.

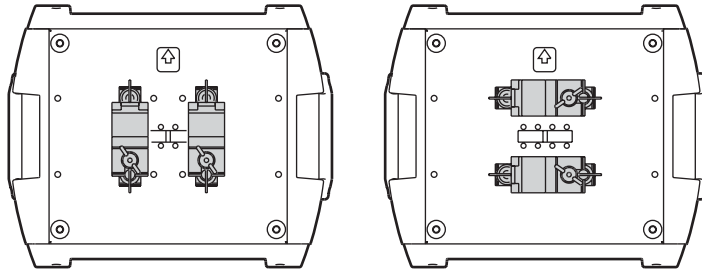

**Figure 6: Clamp bracket positions**

**Warning!** Always use 2 clamps to rig the fixture. Lock each clamp with both 1/4-turn fasteners. The fasteners are locked only when turned fully clockwise.

**Warning!** Attach an approved safety cable to the attachment point labelled “SAFETY WIRE” in the base. Never use the carrying handles for secondary attachment.

## To clamp the fixture on a truss

1. Verify that the rigging clamps are undamaged and can bear at least 10 times the weight of the fixture. Verify that the structure can bear at least 10 times the weight of all installed fixtures, clamps, cables, auxiliary equipment, etc.
2. Bolt each clamp securely to a clamp bracket with an M12 bolt (grade 8.8 or better) and lock nut.
3. Align a clamp with 2 mounting points in the base. Insert the fasteners into the base and turn both levers a full 1/4-turn clockwise to lock. Install the second clamp.
4. Block access under the work area. Working safely from a stable platform, hang the fixture on the truss with the arrow towards the area to be illuminated. Tighten the rigging clamps.
5. Install a safety wire that can bear at least 10 times the weight of the fixture. The attachment point is designed to fit a carabiner clamp.
6. Verify that the tilt lock is released. Verify that there are no combustible materials or surfaces to be illuminated within 1 meter of the fixture, and that there are no flammable materials nearby.

# CONTROL PANEL

The LED control panel allows you to set user options and read fixture information. User settings may be changed remotely via the serial link with the Martin MP-2 Uploader.

## Menu navigation

The DMX address and any status messages (see page 38) are displayed when the MAC 550 Profile is turned on. To enter the menu, press [Menu]. Press [Up] and [Down] to move within the menu. To select a function or submenu, press [Enter]. To escape a function or menu, press [Menu]. See Table 2 on page 33 for a complete list of the menu items.

Note: [Enter] must be pressed and held for a few seconds to enter the utilities menu.

## DMX address and protocol

The DMX address, also known as the start channel, is the first channel used to receive instructions from the controller. For independent control, each fixture must be assigned its own control channels. Two MAC 550 Profiles may share the same address, however, if identical behavior is desired. Address sharing can be useful for diagnostic purposes and symmetric control, particularly when combined with the inverse pan and tilt options.

Depending on the selected DMX mode, the MAC 550 Profile requires 21 or 27 DMX channels. The basic mode uses 21 channels and provides coarse control of all effects plus fine control of gobo rotation, pan, and tilt. The extended mode uses 27 channels and provides the basic mode features plus fine control of the dimmer, color wheels, iris, focus, and zoom.

Note: From software version 2.0, DMX addressing is limited to channels 1-492 (in basic mode) and 1-487 (in extended mode). This makes it impossible to set the DMX address so high that you are left without enough control channels for the fixture.

### To set DMX address and protocol

1. Press [Menu] to enter the main menu.
2. Press [Up] until *ADDR* is displayed. Press [Enter]. To snap to channel 1, press [Enter] and [Up]. Scroll to the desired channel and press [Enter].
3. Select *PSET* from the main menu and press [Enter]. Select *16BT* for basic mode, or *16E\** for extended mode. Press [Enter].

## Tailoring performance

### Movement

The MAC 550 Profile provides several options for optimizing movement for different applications.

- The protocol setting (*PSET*) setting selects the basic (*16BT*) or extended (*16E\**) control mode. Extended mode provides finer position control of the dimmer, color wheels, iris, focus lens, and zoom lens than the basic mode.
- The pan and tilt invert (*PATI*) menu swaps and/or inverts pan and tilt.
- The pan/tilt speed (*PTSP*) menu provides 3 settings: *FAST*, *NORM*, and *SLOW*. *NORM* is best for most applications. *FAST* provides better performance in applications where speed is most important. *SLOW* provides the smoothest movement and is best in long-throw applications with slow movements through narrow angles.
- The studio mode (*STUD*) setting optimizes all effects besides pan and tilt for quietness or speed.

- The shortcuts (*PERS*→*SCUT*) setting determines whether the gobo and color wheels take the shortest path between two positions, crossing the open position if necessary, or always avoid the open position.

## Dimmer

The dimmer curve setting (*PERS*→*DIICU*) provides two options for dimmer behavior. Select *DIM 1* to simulate tungsten dimming or *DIM 2* for more linear dimming.

## Display

The display intensity (*PERS*→*DIINT*) setting controls display brightness. Select *AUTO* for automatic display or manually set the intensity to a level from *10* to *100*.

The display on/sleep setting (*PERS*→*DISP*) determines whether the display remains on (*ON*), or goes to sleep 2 minutes (*2 MN*), or 10 minutes (*10MN*) after the last key press. If the display is in sleep mode, a press on any key or an error message will switch it on again.

To flip the display, press [Up] and [Down] simultaneously.

## Lamp

There are two settings that modify lamp control: Automatic Lamp On (*PERS*→*ALON*) and DMX Lamp Off (*PERS*→*DLDF*).

When *ALON* is *OFF*, the lamp remains off until a “lamp on” command is received. When *ALON* is *ON*, the lamp strikes automatically after the fixture is powered on. When *ALON* is set to *DMX*, the lamp strikes automatically when the fixture receives DMX data, and it extinguishes 15 minutes after DMX data is lost.

When *ALON* is set to either *ON* or *DMX*, the automatic lamp strike timing is staggered to prevent all lamps from striking at once. The delay is determined by the fixture address.

The DMX Lamp Off (*DLDF*) setting allows you to enable (*ON*) or disable (*OFF*) the DMX command that switches off the lamp. The special combination of DMX values listed on page 15 allows you to execute the lamp-off command even when disabled.

## DMX reset

The DMX reset (*PERS*→*DRS*) setting controls the behavior of the reset command. When set to *ON*, the command is fully enabled. When set to *OFF*, the command is disabled to prevent accidental resets. When set to *5SEC*, the command must be sent for five seconds.

## Color blackout

The color blackout (*PERS*→*COLB*) setting enhances blackout effectiveness. When set to *ON*, the color wheels deploy 3 seconds after dimmer blackout. The color filters absorb any tiny amount of light that may escape past the dimmer.

The color wheels take a fraction of a second longer to open than the dimmer blades, however, so setting this feature to *OFF* allows the fixture to snap open more rapidly after a blackout.

## Readouts

### Time

*INFO*→*TIME* provides readouts of fixture hours (*HRS*), lamp hours (*L HR*), and lamp strikes (*L ST*). Under each item is a resettable (*RSET*) increment counter and a non-resettable (*TOTL*) counter for total accumulated hours/strikes since fabrication. To reset an increment counter, display it and then press [Up] until it reads 0.

### Temperature

*INFO*→*TEMP* provides readouts of the head and base temperature in Celsius and Fahrenheit.

### Firmware version

*INFO*→*VER* displays the version number of the installed firmware. The firmware version is also displayed briefly at startup.

## DMX

The DMX log (**DMXL**) menu provides useful information for troubleshooting control problems.

**RATE** displays the DMX refresh rate in packets per second. Values lower than 10 or higher than 44 may result in erratic performance, especially when using tracking control.

**QUAL** displays the quality of the received DMX data as a percentage of packets received. Values much below 100 indicate interference, poor connections, or other problems with the serial data link that are the most common cause of control problems.

**STCD** displays the DMX start code. Packets with a start code other than 0 may cause irregular performance.

The remaining options under **DMXL** display the DMX values received on each channel. If the fixture does not behave as expected, reading the DMX values can help you troubleshoot the problem.

## Manual control

The manual control menu (**MAN**) provides commands for resetting the fixture (**RST**), turning the lamp on (**LON**), and turning the lamp off (**LOFF**). It also permits you to position and move individual effects.

## Service utilities

**Important!** *Enter must be held for several seconds to access the utilities menu.*

### Test sequences

**TSEQ** provides a general test of all effects that can be run without a controller. **UTIL→PCBT** provides routines for circuit board testing that are for service use only.

### Feedback toggles

An on-the-fly position correction system monitors the gobo and color wheels, rotating gobos, and the animation wheel. If a position error is detected, the shutter closes while the effect resets. This feature can be disabled by turning effects feedback (**UTIL→EFFB**) off.

The automatic pan/tilt position correction system may be temporarily turned off under **UTIL→FEBA**. The off setting, however, is not saved and the system will be re-enabled the next time the fixture starts. If the system cannot correct the pan/tilt position within 10 seconds, feedback is automatically disabled.

### Calibration

The calibration menu (**UTIL→CAL**) allows effects to be calibrated. The fixture can be returned to factory calibrated effects and feedback settings using the command (**UTIL→CAL→JFDF**)

### Adjustment

The adjustment menu (**UTIL→ADJ**) provides manual control for making mechanical adjustments. See page 37.

### Software upload

The upload mode command (**UTIL→UPL J**) prepares the fixture for a software update. This command is not necessary, however, as upload mode is engaged automatically by the uploader.

# EFFECTS

This section describes the functions programmed in the MAC 550 Profile DMX protocols. The fixture has two DMX operating modes, basic and extended. The extended mode requires six more DMX channels than the basic mode and provides all features of the basic mode plus fine control of the dimmer, color wheels, iris, zoom, and focus.

Channels references in this section refer to the extended mode protocol unless otherwise noted. The complete DMX protocol begins on page 28.

## Lamp power

### Lamp-on

The lamp-on command on channel 1 closes the relay that provides power to the lamp. When the lamp is on, the command has no effect.

Note: A peak of electric current that can be many times the operating current is drawn for an instant when striking a discharge lamp. Striking many lamps at once may cause a voltage drop large enough to prevent lamps from striking or draw enough current to trip circuit breakers. If sending lamp-on commands to multiple fixtures, program a sequence that strikes lamps one at a time at 5 second intervals.

### Lamp-off

The lamp can be doused from the controller with the lamp-off command. The command must be sent for 5 seconds.

If the lamp-off command is disabled (*PERS* → *DLDF* → *OFF*), the lamp-off command works only if the following effects are selected:

- color wheel 1: slot 1 (DMX 189 - 193)
- color wheel 2: slot 1 (DMX 189 - 193)
- prism: in, no rotation (DMX 80 - 89)
- gobo wheel 1: open (DMX 0 - 11)
- gobo wheel 2: open (DMX 0 or 194 - 202)

## Fixture reset

If an effect loses its indexing and fails to move to programmed positions, the fixture can be reset from the controller by sending the "Reset" command on channel 1.

If DMX reset is disabled (*PERS* → *DRS* → *OFF*), the reset command can only be executed if the conditions listed under "Lamp-off" are met. If it is set to *SSEC*, the reset command must be sent for 5 seconds before executing.

## Dimming and strobe

The mechanical dimmer/shutter system provides smooth, high-resolution 100 percent dimming, instant open and blackout, random and variable strobe effects, and random and variable pulses in which the dimmer snaps open and slowly dims or snaps closed and slowly opens.

Fine control of the dimmer is available in extended mode.

## Color

The two overlapping color wheels each have 8 color filters that scroll continuously, allowing split colors, or in full-color steps. The protocol provides commands for random and continuous color scrolling at different speeds.

Fine control of the color wheels is available in extended mode.

## Rotating gobos

Gobo wheel 1 has six rotating gobos that can be indexed (repeatedly positioned at a programmed angle), rotated continuously, shaken (bounced), and scrolled. The gobo slot and the type of movement are selected on channel 8 and the index angle or rotation speed are selected on channels 9 (coarse) and 10 (fine).

## Static gobos

Gobo wheel 2 has nine static gobos that can be scrolled continuously, allowing split gobo effects, or in full-gobo steps. The protocol provides commands for random and continuous gobo scrolling at different speeds.

## Gobo macros

Channel 12 (9 in basic mode) provides 6 preprogrammed variable-speed macros that use different combinations of color and gobos.

## Gobo animation

The gobo animation system is designed to create animated effects such as rising flames or windswept clouds when combined with overlapping gobos.

Channel 13 (10 in basic mode) sets the animation wheel's rotation mode (indexed or continuous), and direction of movement. This channel also provides 5 programmed animation macros.

Channel 14 sets the wheel's index angle if indexed rotation is selected on channel 13, or its rotation speed and direction if continuous rotation is selected on channel 13.

## Prism and iris

The prism may be inserted and rotated clockwise and counterclockwise at varying speeds. The prism control channel also provides 8 programmed macros.

The iris channel controls the diameter of the iris opening and provides variable speed pulsing effects. Fine control of the iris is provided in extended mode.

## Focus and zoom

The focus lens focusses the beam from approximately 2 meters (6.5 feet) to infinity. The separate zoom lens varies the focused beam angle from 14° to 30°. Fine control of focus and zoom is provided in extended mode.

## Pan and tilt

Pan and tilt are controlled on channels 22 to 25 (16 to 19 in basic mode). The coarse control channels set the first 8 bits (the most significant byte or MSB), and the fine channels set the second 8 bits (the least significant byte or LSB) of the 16-bit control byte. In other words, the fine channel works within the position set by the coarse channel.

## Speed channels

### Tracking versus vector control

***Important!*** *Effect movement may be rough and unpredictable if controller fade times are combined with vector speed values.*

The speed channels provide two methods for controlling speed that are known as “tracking” and “vector”.

With tracking control, the speed at which effects move is determined by a cross-fade time programmed on the controller. With this method, the controller divides a movement into tiny steps that the fixture “tracks”. Tracking control is enabled by setting the speed channels to one of the tracking values listed in the DMX protocol.

With vector control, speed is set with a DMX value on the speed channel. This provides a way to control speed on controllers without cross-faders. Vector control can also provide smoother movement, particularly at slow speeds, with controllers that send slow or irregular tracking updates. When using vector control, the controller’s cross-fade time, if available, must be 0.

### Blackout

When “blackout while moving” is selected on a speed channel, the shutter closes when an effect moves to make the transition invisible. The shutter opens when the movement is complete. This function is available for pan, tilt, color, gobo, and prism change.

### Personality overrides

The pan/tilt speed channel provides tracking values that allow you to override the pan/tilt speed setting from the controller.

The effects speed channel provides values for overriding the shortcuts setting for the color and gobo wheels.

# OPTICAL CONFIGURATION

## Color wheels

The MAC 550 Profile provides two overlapping color wheels with 8 interchangeable color filters and an open position. Color wheel 1 is closer to the lamp and color wheel 2 is closer to the lens. The illustrations show the filter positions as seen from the lens. Refer to the DMX protocol for filter names.

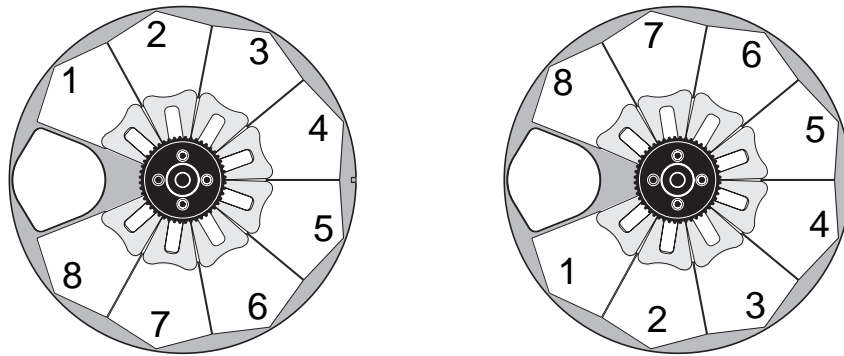

Figure 7: Filter positions, wheel 1 (left) and wheel 2 (right), seen from lens

## To replace a color filter

Note: Use only genuine MAC 550 color filters.

1. Disconnect the fixture from AC power and allow it to cool.
2. Remove the bottom cover.
3. Turn the color wheel to access the desired filter position. Press the filter forwards slightly to release it and then grasp it by the edges and remove. If your fingers are too large, protect the glass with a piece of paper that has been folded several times and grasp the filter with needle nose pliers.
4. To insert a filter, slide it under the retention spring until it snaps into place.
5. Replace the cover before applying power.

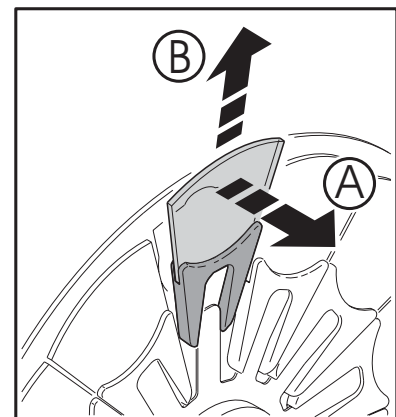

Figure 8: Filter

## Gobos

Gobo wheel 1 provides 6 rotating gobos; gobo wheel 2 provides 9 static gobos. The standard gobo configuration is shown in Figure 9. All gobos are interchangeable with the following limitations:

- On wheel 1 (rotating), the gobo retention spring works with gobos up to 3 mm in thickness. Thicker gobos can be glued to the holder with a UV adhesive or Loctite 330 Multibond with Activator.
- On wheel 2 (static), the maximum thickness for gobos is 1.1 mm.

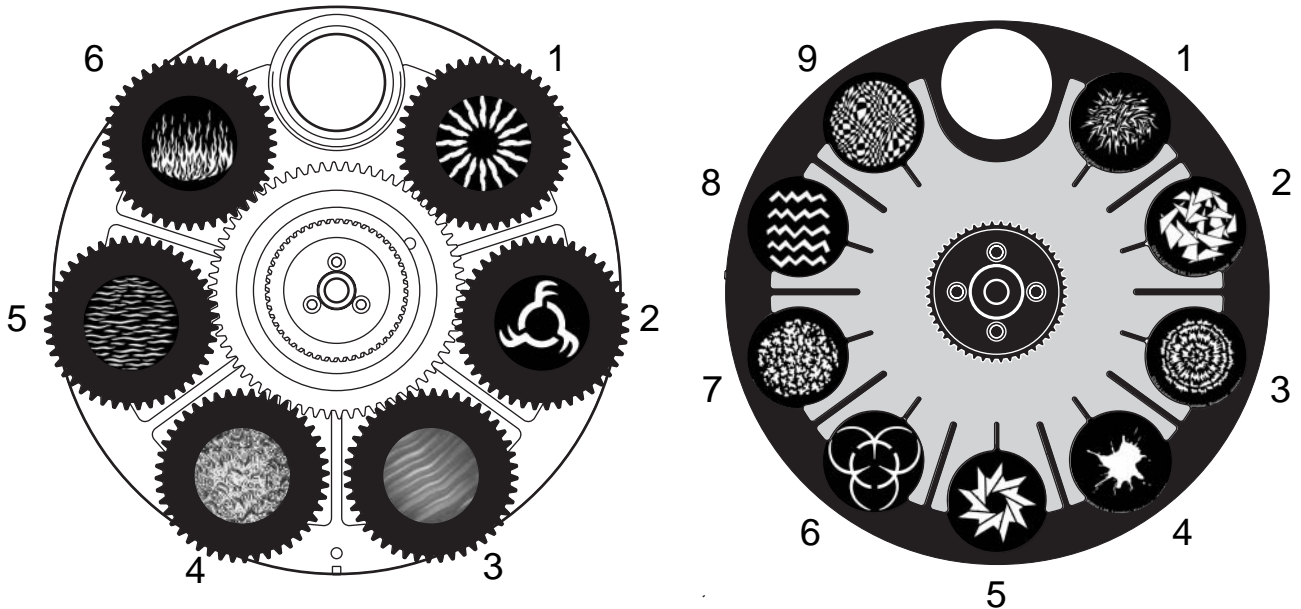

Figure 9: Gobo wheels as seen from front lens

### Custom gobos

Martin can provide many additional gobos for the MAC 550 Profile, which accepts the same size gobos as the MAC 500. For more information, please visit the Martin web site at [www.martin.com](http://www.martin.com).

Custom glass gobos should be made with the artwork reversed on the coated side. This orientation minimizes reflections but is not critical.

While glass gobos are generally the most durable, satisfactory results can be obtained at less expense with aluminum gobos. Custom stainless steel gobos can also be used, however they can warp, losing sharpness, in a matter of hours. The useful life will depend on the gobo pattern and the projection cycle. Consult your gobo supplier for more information.

For best results, custom gobos should meet the specifications listed on page 42.

## GOBO ORIENTATION IN THE MAC 550 PROFILE

The orientations shown in Figure 10 are correct in most cases, but consult your Martin dealer or gobo supplier if you are in any doubt about the orientation of a specific gobo type.

### Coated Glass Gobos

Focus is easiest to maintain if all coated gobos in a fixture are installed with their coatings as close as possible to the same plane of focus. The coated gobos in the MAC 550 Profile are factory-installed in this position. However, if there is an unusually high risk of heat damage on a custom coated gobo, the first priority is normally to ensure that more reflective sides face towards the lamp. If in doubt, install coated gobos with the more reflective (silvered) side towards the lamp, or consult your Martin dealer or gobo supplier.

#### More reflective side towards lamp

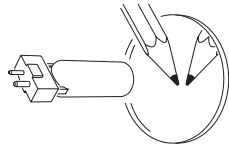

To minimize the risk of gobo overheating and damage, turn the more reflective side of a coated gobo towards the lamp.

#### Less reflective side away from lamp

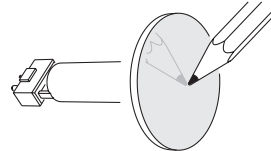

The less reflective side of a coated gobo will absorb less heat if it faces away from the lamp.

To determine which side of a gobo is coated, hold an object up to it. On the uncoated side, there is a space between the object and its reflection and the edge of the gobo can be seen when looking through the glass.

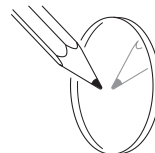

Uncoated side

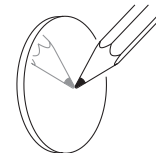

Coated side

### Textured Glass Gobos

#### Textured side towards lamp

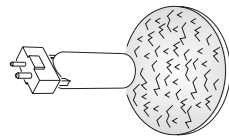

#### Smooth side away from lamp

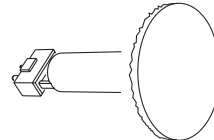

Textured glass gobos in the MAC 550 Profile sit most squarely in the gobo wheel with the textured side towards the lamp. If in doubt, consult your Martin dealer or gobo supplier.

### Metal Gobos

#### Reflective side towards lamp

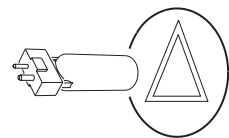

#### Black side away from lamp

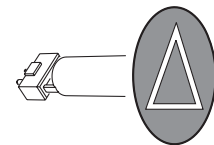

### Image / text Gobos

#### True image towards lamp

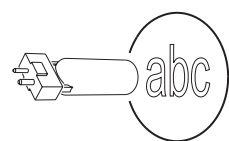

#### Reversed image away from lamp

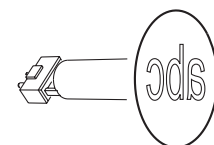

Figure 10. Correct gobo orientation

## To replace rotating gobos

**Important!** The gobo can fall out if the spring is inserted backwards.

1. Disconnect the fixture from power and allow it to cool.
2. Position the head upside down and remove the bottom head cover. Turn the gobo wheel to the desired position. Grasp the holder by the teeth and pull the holder lightly towards the front lens to release the holder and remove it from the wheel.
3. With a small screwdriver or similar, unhook the end of the gobo spring furthest from the gobo and pull out the spring. Drop the gobo out of the holder.
4. Insert the new gobo in the holder with the side that faces towards the lamp facing upwards, towards the spring (see Figure 10 and Figure 11).
5. Insert the spring with the narrow end against the gobo. To identify the narrow end, press the spring flat: the narrow end is on the inside. Push the end of the spring in under the lip of the holder.
6. Verify that the gobo is seated flush against the holder. Press the spring as flat as possible against the back of the gobo.
7. Work the rim of the gobo holder under both clips and snap the gobo holder back into position. If necessary, a small screwdriver or similar tool may be used to pry the clips away from the wheel.
8. Replace the bottom cover and release the tilt lock before applying power.

Figure 11: Rotating gobo holder

## To replace static gobos

1. Disconnect the fixture from power and allow it to cool.
2. Remove the top head cover.
3. Turn the gobo wheel to the desired position. Press the gobo from the lamp side to release. Remove the gobo.
4. To insert a gobo, orient the gobo as shown in Figure 10 and place the edges under the retention spring. Verify that the gobo is centered in the opening.
5. Replace the top head cover and release the tilt lock before applying power.

## Animation wheel

The MAC 550 Profile comes with the “Radial breakup” animation wheel installed. Three additional stock patterns are available.

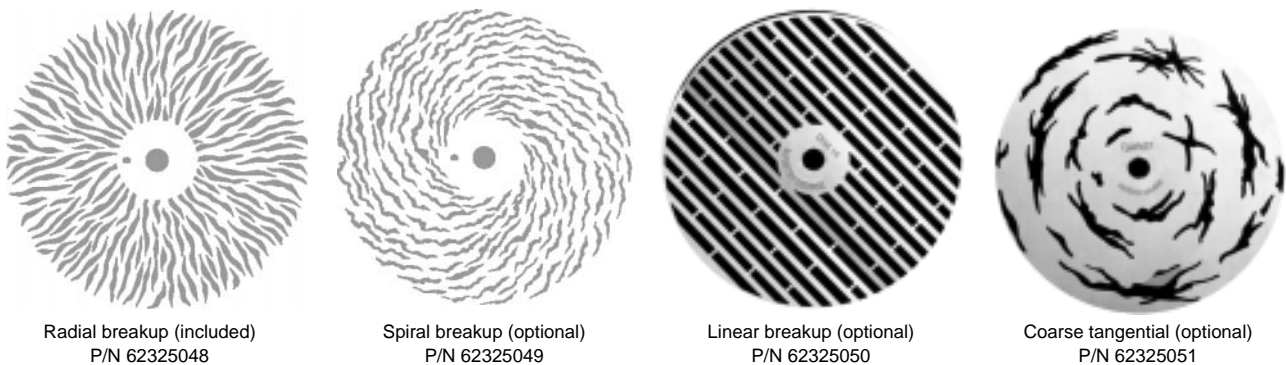

Figure 12: MAC 550 Profile animation wheels

## To replace the gobo animation wheel

Note: The replacement animation wheel can be inserted with the magnet in or out to suit your application. In fixed applications, install the wheel with the magnet forwards, away from the drive mechanism, for easier

removal. In touring or similar applications where the fixture is frequently moved, install the animation wheel with the magnet in towards the drive mechanism for a more secure hold.

1. Disconnect the fixture from power and allow it to cool.
2. Remove the gobo module as described on page 23.
3. Stand the module on the work surface with the cooling fans to your left and the color wheel to your right.
4. Bring the animation wheel to the side of the module closest to you by turning the black belt on the right.
5. To avoid bending the animation wheel while removing, break the magnet's initial hold by prying the wheel off with a screwdriver inserted from the back. Once you have broken the hold, you can safely grasp the wheel by the edge and remove.
6. Orient the replacement wheel with the magnet in or out to suit your application. (See note.) Place the wheel over the drive mechanism and align the hole in the wheel with the drive pin.
7. Reinstall the gobo module. Verify that the guide pins are correctly seated and that the module is securely locked.
8. Replace the head cover and release the tilt lock before applying power.

## Prism

The MAC 550 Profile is supplied with a three-facet rotating prism.

### To replace the prism

1. Disconnect the fixture from power and allow it to cool.
2. Position the head top side up, secure it with the tilt lock and remove the top head cover. The prism sits in the zoom/focus module (see Figure 13).
3. See Figure 14. The prism wheel is held between three pulleys. The lower pulley is spring-loaded. Push the prism down until it is released from the upper two pulleys, then lift it forwards out of the module.
4. Ensure the prism drive belt engages correctly during reassembly.

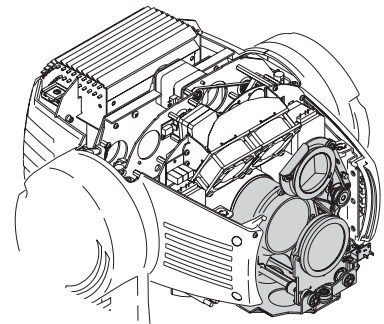

Figure 13: Zoom/focus module

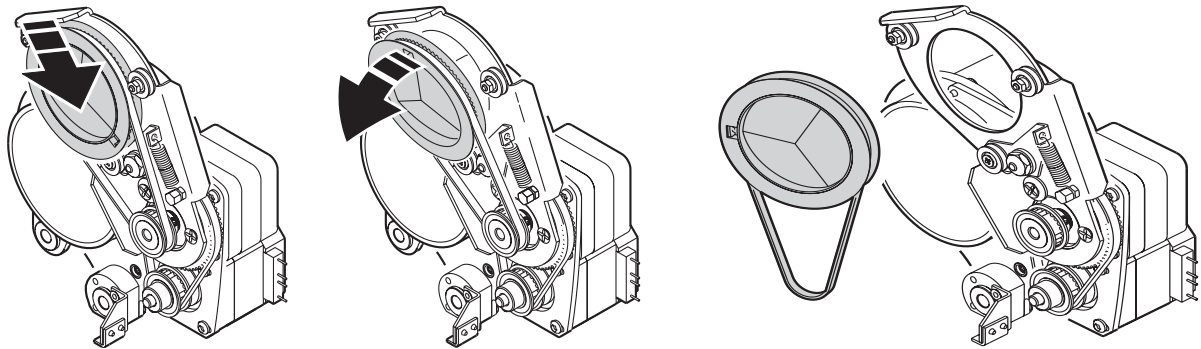

Figure 14: Removing the prism

5. Replace all covers and release the tilt lock before reapplying power.

# ROUTINE MAINTENANCE

The MAC 550 Profile requires routine cleaning. The schedule depends heavily on the operating environment. It is essential to follow the cleaning guidelines given later in this section.

Refer any service operation that is not described here to a qualified Martin technician.

**Important!** *Excessive dust, smoke fluid, and particulate buildup degrades performance, causes overheating and will damage the fixture. Damage caused by inadequate maintenance is not covered by the warranty.*

**Warning!** *Disconnect the fixture from power before removing any cover.*

## Tilt lock

**Important!** *Release the tilt lock before operating the fixture.*

The tilt position of the head can be locked for transportation and service with the tilt lock. To lock or unlock the head, pull the lock out and turn it one-quarter turn in either direction.

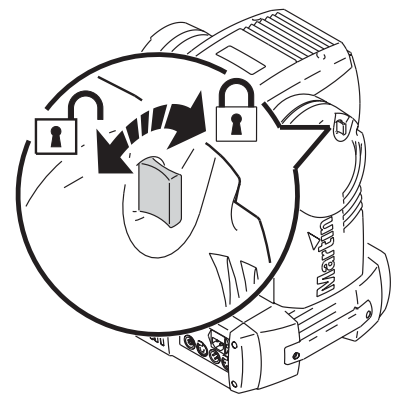

Figure 15: Tilt lock

## Disassembly

### To remove the gobo module

1. Disconnect the fixture from power and allow it to cool.
2. Turn the four retaining screws in the top and bottom head covers one quarter-turn counter-clockwise to release the covers.
3. Remove the front lens by twisting one quarter-turn counter-clockwise.

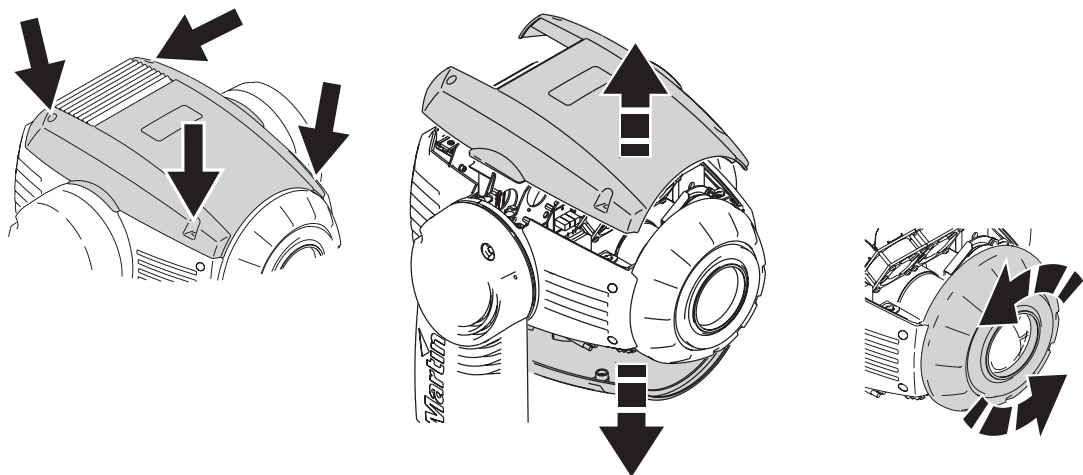
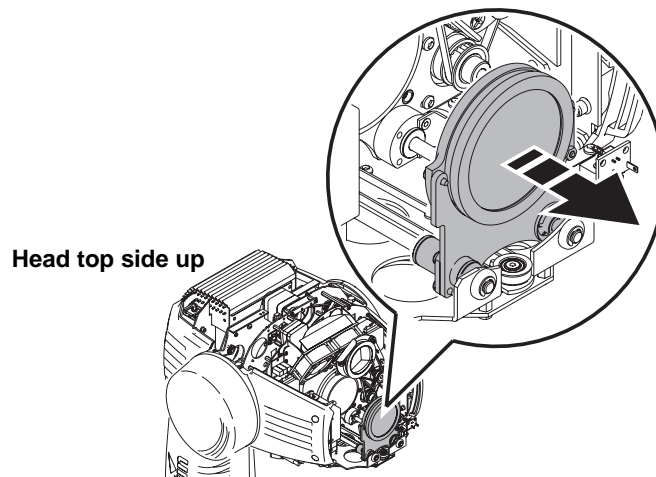

Figure 16: Releasing top and bottom covers and removing front lens

4. Position the head top side up so that you have access through the top. Holding the focus lens by its base, slide it out to its limit at the front of the fixture as shown in Figure 17.



**Figure 17: Moving the focus lens forward**

5. Flip the head upside-down. Move the prism lens to its forward limit by pulling on its belt as shown in Figure 18.

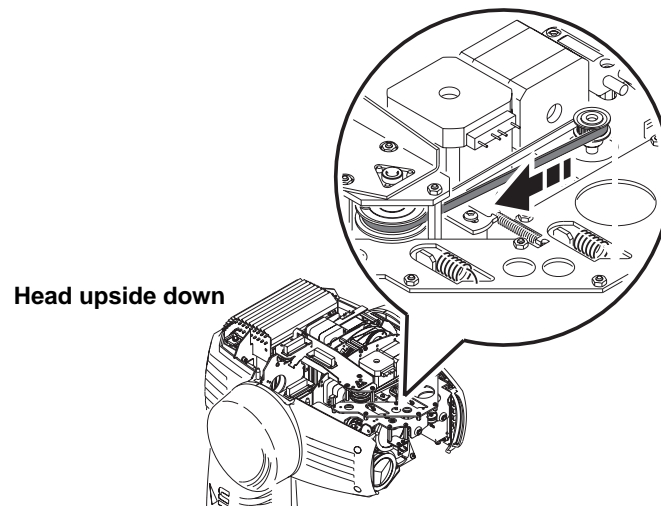

**Figure 18: Moving the prism lens forward**

6. Flip the head top side up again. To avoid bending the gobo animation wheel when you remove the module, move the wheel in towards the center of the module by inserting a finger and rotating the positioning belt idler pulley at the top of the module as shown in Figure 19.

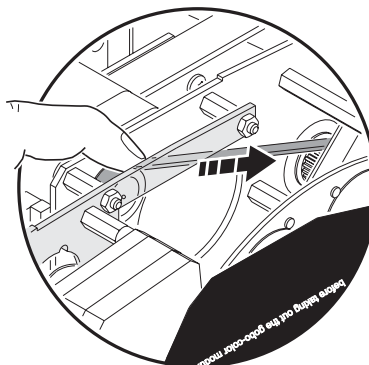

**Figure 19: Retracting the gobo animation wheel**

7. Unlock the gobo module by pulling the levers on each side towards the center. Lift the module up 1 cm (0.5 in.) and release the levers. Lift the module straight up to remove from the head.

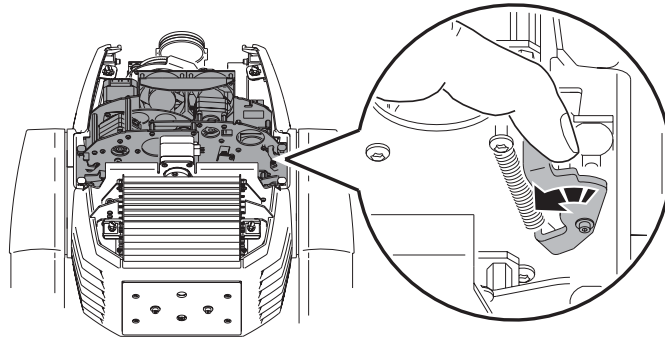

**Figure 20: Gobo module locking levers**

8. When reinstalling the module, verify that the guide pins are correctly seated and that the module is securely locked.

### To remove the dimmer module

The dimmer module can be removed for service and to access the lamp cooling fans and heat shield:

1. Remove the gobo module as described above.
2. Like the gobo module, the smaller dimmer module is also released by pulling on two levers. Lift the module straight up to remove from the head.
3. When reinstalling, verify that the guide pins are correctly seated and that the module is securely locked.

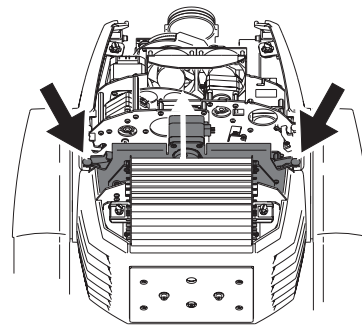

**Figure 21: Dimmer module locking levers**

## Cleaning

Regular cleaning is very important for fixture life and performance. Buildup of dust, dirt, smoke particles, fog fluid residues, etc. degrades the fixture's light output and cooling ability.

Cleaning schedules for lighting fixtures vary greatly depending on the operating environment. It is therefore impossible to specify precise cleaning intervals for the MAC 550 Profile. Cooling fans suck in airborne dust and smoke particles, and in extreme cases fixtures may require cleaning after surprisingly few hours of operation. Environmental factors that may result in a need for frequent cleaning include:

- Use of smoke or fog machines.
- High airflow rates (near air conditioning vents, for example).
- Presence of cigarette smoke.
- Airborne dust (from stage effects, building structures and fittings or the natural environment at outdoor events, for example).

If one or more of these factors is present, inspect all fixtures within their first 24 hours of operation to see whether cleaning is necessary. Check again at frequent intervals. This procedure will allow you to assess cleaning requirements in your particular situation. Experience and consultation with your Martin service representative will help you determine an appropriate maintenance schedule.

Use care when cleaning optical components and work in a clean, well lit area. The coated surfaces are fragile and easily scratched. Do not use solvents that can damage plastic or painted surfaces.

### To clean the fixture

1. Disconnect the fixture from power and allow the components to cool completely.
2. Remove the covers, front lens and gobo and dimmer modules as described earlier.
3. Vacuum or gently blow away dust and loose particles with compressed air.

4. Carefully clean the optical components. Remove smoke and other residues with cotton swabs or unscented tissues moistened with isopropyl alcohol. A commercial glass cleaner may be used, but residues must be removed with distilled water. Clean with a slow circular motion from center to edge. Dry with a clean, soft and lint-free cloth or compressed air. Remove stuck particles with an unscented tissue or cotton swab moistened with glass cleaner or distilled water. Do not rub the surface: lift the particles off with a soft repeated press.
5. Remove dust from the head fans and air vents with a soft brush, cotton swab, vacuum, or compressed air.
6. On each side of the head, remove the 2 screws that hold the side covers. Slide the covers forward to remove. Clean the air filters or replace them. If they are saturated with smoke fluid, etcetera, soak them in warm soapy water and blot dry. Position the filters on the side covers and reinstall. See Figure 22.
7. Reassemble the head.
8. Remove the screws from the side cover/grill on the front of the base (front is indicated by an arrow on the bottom). Remove the top cover from the front of the base. Lift the power supply / ballast module up and out to expose the base fans for inspection and cleaning.
9. Reinstall the power supply / ballast module and base cover.

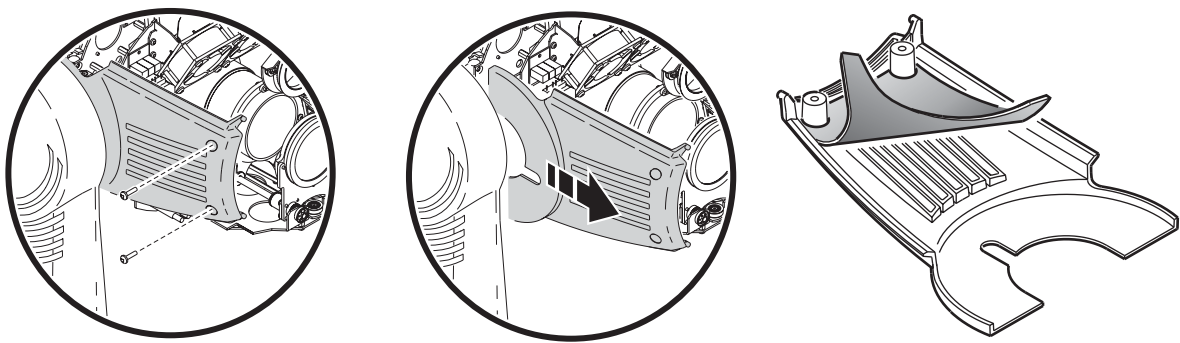

**Figure 22: Air filter replacement**

## Lubrication

The MAC 550 Profile does not require lubrication under normal circumstances. The slides for the zoom and focus lens cars are lubricated with a long-lasting teflon-based grease that can be reapplied by a Martin service partner if necessary.

## Lampholder replacement

The lamp holder used in the MAC 550 Profile eventually wears out due to the high voltages that pass through the contacts. Service life will vary, but as a rule you should plan to replace the holder every 4000 hours approximately.

Wear begins to show up as discoloration at the contact surfaces. When this happens, resistance increases and the lamp becomes harder to strike. If this process is allowed to continue, the lamp is likely to fail prematurely.

Each time the lamp is replaced, inspect the lamp holder and have it replaced by a qualified technician as soon as there are signs of discoloration or pitting at the contact surfaces. Damage caused by failure to replace a worn and/or discolored lamp holder is not covered by the warranty.

## Software installation

Software updates are available from the Martin web site and can be installed via the data link with a Martin upload device.

The following are required in order to install software.

- The MAC 550 Profile update file, available for download from the User Support Area of the Martin website (<http://www.martin.com>).
- The Martin Software Uploader program, version 5.0 or later, available for download from the User Support Area of the Martin website.
- A Martin MP-2 Uploader connected to a Windows 95/98/ME/2000/XP PC, or one of the PC controller DMX interfaces supported by the Martin Software Uploader software.

## **To install software, normal method**

Please refer to the MP-2 user manual and the Martin Software Uploader online help file.

## **To install software if all else fails (boot sector update)**

Note: Use this procedure only if the firmware is totally corrupted, which is evident if the control panel does not respond when power is applied, or if the software update notes call for a boot sector update. In the event of a check sum error, repeat the normal upload procedure.

1. Disconnect the fixture from power.
2. Remove the side cover from the side of the base that has the control panel to expose the main PCB.
3. Locate the "BOOT" jumper on the main PCB (see page 41) and move the jumper cap to the "INIT" position.
4. Perform a boot mode upload as described in the uploader documentation.
5. When the upload is complete, disconnect the fixture from power and move the jumper back to the "DISABLE" position.
6. Reassemble the base.

# DMX PROTOCOL

Basic Mode	Extended Mode	DMX Value	Percent	Function
1	1	0 - 19	0 - 7	<b>Shutter, Strobe, Reset, Lamp On/Off</b> Shutter closed
		20 - 49	8 - 19	Shutter open
		50 - 72	20 - 28	Strobe, fast to slow
		73 - 79	29 - 31	Shutter open
		80 - 99	32 - 39	Opening pulse, fast to slow
		100 - 119	40 - 47	Closing pulse, fast to slow
		120 - 127	48 - 50	Shutter open
		128 - 147	51 - 57	Random strobe, fast
		148 - 167	58 - 65	Random strobe, medium
		168 - 187	66 - 73	Random strobe, slow
		188 - 190	74 - 74	Shutter open
		191 - 193	75	Random opening pulse, fast
		194 - 196	76	Random opening pulse, slow
		197 - 199	77	Random closing pulse, fast
		200 - 202	78 - 79	Random closing pulse, slow
		203 - 207	80 - 81	Shutter open
		208 - 217	82 - 85	Reset fixture*
		218 - 227	86 - 89	Shutter open
		228 - 237	90 - 93	Lamp on
		238 - 247	94 - 97	Shutter open
248 - 255	98 - 100	Lamp off*		
				<p><i>*If disabled in software, this command works only if the following effects are selected:</i></p> <ul style="list-style-type: none"> <li>• Color wheel 1 to slot 1</li> <li>• Color wheel 2 to slot 1</li> <li>• Prism in, no rotation</li> <li>• Gobo wheel 1 open</li> <li>• Gobo wheel 2 open</li> </ul>
2	2	0 - 255	0 - 100	<b>Coarse Dimmer (MSB)</b> Closed to open
-	3	0 - 255	0 - 100	<b>Fine Dimmer (LSB)</b> Closed to open
3	4	0	0	<b>Color Wheel 1, Coarse (MSB)</b> <i>Continuous Scroll: full color positions</i> Open
		17	4	Slot 1 (Red 308)
		34	9	Slot 2 (Magenta 507)
		51	13	Slot 3 (Purple 502 IAD)
		68	17	Slot 4 (Blue 104)
		85	22	Slot 5 (Green 206)
		102	26	Slot 6 (Yellow 601)
		119	30	Slot 7 (Orange 306M)
		136	35	Slot 8 (Purple 509)
		153	56	Open
		154 - 158	66 - 67	<i>Stepped Scroll</i> Slot 8 (Purple 509)
		159 - 163	67 - 68	Slot 7 (Orange 306M)
		164 - 168	69 - 70	Slot 6 (Yellow 601)
		169 - 173	70 - 72	Slot 5 (Green 206)
		174 - 178	72 - 73	Slot 4 (Blue 104)
		179 - 183	74 - 75	Slot 3 (Purple 502 IAD)
		184 - 188	75 - 76	Slot 2 (Magenta 507)
		189 - 193	77 - 78	Slot 1 (Red 308)
		194 - 198	80 - 81	Open
		199 - 219	82 - 88	<i>Continuous Rotation</i> CW, fast to slow
220 - 240	89 - 96	CCW, slow to fast		
241 - 245	96 - 97	<i>Random Color</i> Fast		
246 - 250	98 - 98	Medium		
251 - 255	99 - 100	Slow		
-	5	0 - 255	0 - 100	<b>Color Wheel 1, Fine (LSB)</b>

Basic Mode	Extended Mode	DMX Value	Percent	Function	
4	6	<b>Color Wheel 2, Coarse (MSB)</b>			
		<i>Continuous Scroll: full color positions:</i>			
		0	0	Open	
		17	4	Slot 1 (Green 208)	
		34	9	Slot 2 (Blue 102)	
		51	13	Slot 3 (Pink 312)	
		68	17	Slot 4 (Red 301)	
		85	22	Slot 5 (Yellow 603)	
		102	26	Slot 6 (Half Minus Green)	
		119	30	Slot 7 (CTC 5500-4200)	
		136	35	Slot 8 (CTC 3200-4100)	
		153	56	Open	
		<i>Stepped Scroll</i>			
		154 - 158	61 - 63	Slot 8 (CTC 3200-4100)	
		159 - 163	67 - 68	Slot 7 (CTC 5500-4200)	
		164 - 168	69 - 70	Slot 6 (Half Minus Green)	
		169 - 173	70 - 72	Slot 5 (Yellow 603)	
		174 - 178	72 - 73	Slot 4 (Red 301)	
		179 - 183	74 - 75	Slot 3 (Pink 312)	
		184 - 188	75 - 76	Slot 2 (Blue 102)	
189 - 193	77 - 78	Slot 1 (Green 208)			
194 - 198	80 - 81	Open			
<i>Continuous Rotation</i>					
199 - 219	82 - 88	CW, fast to slow			
220 - 240	89 - 96	CCW, slow to fast			
<i>Random color</i>					
241 - 245	96 - 97	Fast			
246 - 250	98 - 98	Medium			
251 - 255	99 - 100	Slow			
-	7	0 - 255	0 - 100	<b>Color Wheel 2, Fine (LSB)</b>	
5	8	<b>Gobo Wheel 1, Gobo and Function Selection</b>			
		<i>Select gobo with indexed position</i>			
		0 - 11	0 - 4	Open	
		12 - 15	4 - 5	Slot 1 (Fire Sun)	
		16 - 19	6 - 7	Slot 2 (Rotator)	
		20 - 23	7 - 9	Slot 3 (Indigo Waves)	
		24 - 27	9 - 10	Slot 4 (Limbo)	
		28 - 31	11 - 12	Slot 5 (Water 4)	
		32 - 35	12 - 13	Slot 6 (Flames 6)	
		<i>Select gobo with continuous rotation</i>			
		36 - 39	14 - 15	Slot 1 (Fire Sun)	
		40 - 43	15 - 16	Slot 2 (Rotator)	
		44 - 47	17 - 18	Slot 3 (Indigo Waves)	
		48 - 51	18 - 20	Slot 4 (Limbo)	
		52 - 55	20 - 21	Slot 5 (Water 4)	
		56 - 59	22 - 23	Slot 6 (Flames 6)	
		<i>Select gobo with indexed position and shake</i>			
		60 - 71	23 - 27	Gobo 1, slow to fast	
		72 - 83	28 - 32	Gobo 2, slow to fast	
		84 - 95	33 - 37	Gobo 3, slow to fast	
		96 - 107	37 - 107	Gobo 4, slow to fast	
		108 - 119	42 - 46	Gobo 5, slow to fast	
		120 - 131	47 - 51	Gobo 6, slow to fast	
		<i>Select gobo with continuous rotation and shake</i>			
		132 - 143	52 - 56	Gobo 6, slow to fast	
		144 - 155	56 - 61	Gobo 5, slow to fast	
		156 - 167	61 - 65	Gobo 4, slow to fast	
		168 - 179	66 - 70	Gobo 3, slow to fast	
		180 - 191	70 - 75	Gobo 2, slow to fast	
		192 - 203	75 - 79	Gobo 1, slow to fast	
<i>Gobo scroll with continuous rotation</i>					
204 - 229	80 - 90	CW scroll, slow to fast			
230 - 255	90 - 100	CCW scroll, fast to slow			

Basic Mode	Extended Mode	DMX Value	Percent	Function
6	9	0 - 255	0 - 100	<b>Gobo Wheel 1, Coarse Rotation (MSB)</b> <i>If indexed position is selected</i> Rotation angle, 0 - 395°
		0 - 2	0	<i>If continuous rotation is selected</i> No rotation
		3 - 127	1 - 50	CW, slow - fast
		128 - 252	51 - 99	CCW, fast - slow
		253 - 255	100	No rotation
7	10	0 - 255	0 - 100	<b>Gobo Wheel 1, Fine Rotation (LSB)</b>
8	11	0	0	<b>Gobo Wheel 2</b> <i>Continuous Scroll: full positions</i> Open
		11	4	Slot 1 (Crackle)
		22	8	Slot 2 (Triangles 2)
		33	13	Slot 3 (Tye Dye)
		44	17	Slot 4 (Splodge)
		55	21	Slot 5 (Ninestar)
		66	26	Slot 6 (Bio)
		77	30	Slot 7 (Leaf Breakup (Medium))
		88	34	Slot 8 (Zig Zags)
		99	39	Slot 9 (Two Tone)
		110 - 112	43 - 44	Open
		113 - 121	44 - 47	<i>Stepped Scroll</i> Slot 9 (Two Tone)
		122 - 130	48 - 51	Slot 8 (Zig Zags)
		131 - 139	51 - 54	Slot 7 (Leaf Breakup (Medium))
		140 - 148	55 - 58	Slot 6 (Bio)
		149 - 157	58 - 61	Slot 5 (Ninestar)
		158 - 166	62 - 65	Slot 4 (Splodge)
		167 - 175	65 - 68	Slot 3 (Tye Dye)
		176 - 184	68 - 72	Slot 2 (Triangles 2)
		185 - 193	72 - 76	Slot 1 (Crackle)
194 - 202	76 - 79	Open		
203 - 221	79 - 87	<i>Continuous Rotation</i> CW, fast - slow		
222 - 240	87 - 94	CCW, slow - fast		
241 - 245	94 - 96	<i>Random Gobo</i> Fast		
246 - 250	96 - 98	Medium		
251 - 255	98 - 100	Slow		
9	12	0 - 15	0 - 5	<b>Gobo/Color Macros</b> No macro
		16 - 55	6 - 21	Gobo wheel 2, shake, slow - fast
		56 - 95	22 - 37	Color wheel 1, shake, slow - fast
		96 - 135	37 - 53	Color wheel 2, shake, slow - fast
		136 - 175	53 - 68	Gobo wheel 2 and color 1, shake, slow - fast
		176 - 215	69 - 84	Gobo wheel 2 and color 2, shake, slow - fast
		216 - 255	85 - 100	Gobo wheel 2, color 1, and color 2, shake, slow - fast
10	13	0 - 9	0 - 3	<b>Gobo Animation Angle and Function</b> Open
		10 - 19	4 - 7	Vertical indexed position
		20 - 29	8 - 11	Horizontal indexed position
		30 - 39	12 - 15	Vertical continuous rotation
		40 - 49	16 - 19	Horizontal continuous rotation
		50 - 139	20 - 54	Angled indexed position, vertical to horizontal
		140 - 229	55 - 89	Angled continuous rotation, horizontal to vertical
		230 - 235	90 - 92	Open
		236 - 239	93	<i>Animation macros</i> Macro 1
		240 - 243	94 - 95	Macro 2
		244 - 247	96	Macro 3
		248 - 251	97 - 98	Macro 4
		252 - 255	99 - 100	Macro 5

Basic Mode	Extended Mode	DMX Value	Percent	Function
11	14	0 - 255	0 - 100	<b>Gobo Animation Wheel, Angle / Speed</b> <i>If indexed position is selected</i> Rotation angle, min.- max.
		0 - 2	0	<i>If continuous rotation is selected</i> No rotation
		3 - 127	1 - 50	CCW, slow - fast
		128 - 252	51 - 99	CW, fast - slow
		253 - 255	100	No rotation
12	15	0 - 19	0 - 7	<b>Prism</b> <i>Rotation</i> Prism out
		20 - 79	8 - 31	Prism in, CCW rotation, fast - slow
		80 - 89	31 - 35	Prism in, no rotation
		90 - 149	35 - 58	Prism in, CW rotation, slow - fast
		150 - 215	59 - 84	Prism out
				<i>Prism Macros</i>
		216 - 220	84 - 86	Macro 1
		221 - 225	87 - 88	Macro 2
		226 - 230	89 - 90	Macro 3
		231 - 235	91 - 92	Macro 4
		236 - 240	93 - 94	Macro 5
		241 - 245	95 - 96	Macro 6
		246 - 250	96 - 98	Macro 7
		251 - 255	98 - 100	Macro 8
		13	16	0 - 199
200 - 215	78 - 84			Closed
216 - 229	85 - 89			Opening pulse, fast - slow
230 - 243	90 - 94			Closing pulse, fast - slow
244 - 246	95 - 96			Fast random opening pulse
247 - 249	97			Slow random opening pulse
250 - 252	98 - 99			Fast random closing pulse
253 - 255	100			Slow random closing pulse
-	17			0 - 255
14	18	0 - 255	0 - 100	<b>Coarse Focus (MSB)</b> Infinity - near
-	19	0 - 255	0 - 100	<b>Fine Focus (LSB)</b>
15	20	0 - 255	0 - 100	<b>Coarse Zoom (MSB)</b> Flood - spot
-	21	0 - 255	0 - 100	<b>Fine Zoom (LSB)</b>
16	22	0 - 255	0 - 100	<b>Coarse Pan (MSB)</b> Left - right
17	23	0 - 255	0 - 100	<b>Fine Pan (LSB)</b> Left - right
18	24	0 - 255	0 - 100	<b>Coarse Tilt (MSB)</b> Left - right
19	25	0 - 255	0 - 100	<b>Fine Tilt (LSB)</b> Left - right
20	26	0 - 2	0 - 1	<b>Pan/Tilt Speed</b> Tracking
		3 - 242	1 - 95	Fast - slow
		243 - 245	96	Tracking, PTSP SLOW (menu override)
		246 - 248	96 - 97	Tracking, PTSP NORM (menu override)
		249 - 251	98	Tracking, PTSP FAST (menu override)
		252 - 255	99 - 100	Blackout while moving

Basic Mode	Extended Mode	DMX Value	Percent	Function
21	27			<b>Effects Speed</b>
				<i>Dimmer, Animation, Zoom, and Focus Speed</i>
		0 - 2	0 - 1	Tracking
		3 - 245	1 - 96	Fast - slow
		246 - 251	96 - 98	Tracking
		252 - 255	99 - 100	Maximum speed
				<i>Color Speed</i>
		0 - 2	0 - 1	Tracking
		3 - 245	1 - 96	Speed, fast - slow
		246 - 248	96 - 97	Tracking, SCUT OFF (menu override)
		249 - 251	98	Tracking, SCUT ON (menu override)
		252 - 255	99 - 100	Blackout while moving
				<i>Gobo Selection Speed</i>
		0 - 245	0 - 96	Normal (no blackout)
		246 - 248	96 - 97	Normal, SCUT OFF (menu override)
		249 - 251	98	Normal, SCUT ON (menu override)
		252 - 255	99 - 100	Blackout while moving
				<i>Gobo Indexing Speed</i>
		0 - 2	0 - 1	Tracking mode
		3 - 245	1 - 96	Fast - slow
246 - 251	96 - 98	Tracking		
252 - 255	99 - 100	Blackout while moving		
		<i>Prism Speed</i>		
0 - 251	0 - 98	Normal (no blackout)		
252 - 255	99 - 100	Blackout while moving		

# CONTROL MENU

Menu	Item	Options	Notes (Default settings in bold print)
<i>ADDR</i>	-	<i>1-492</i> (16 bit) <i>1-487</i> (16 bit ext.)	DMX address (factory default = 1)
<i>PSET</i>	-	<i>16BT</i>	<b>Basic DMX mode with 2-channel (coarse and fine) control of gobo rotation, pan, and tilt.</b>
		<i>16EX</i>	Extended DMX mode with basic mode features plus 2-channel control of dimmer, color wheels 1 and 2, iris, focus, and zoom.
<i>PATI</i>	<i>SWAP</i>	<i>ON</i>	Map DMX pan control to tilt channel and vice versa.
		<i>OFF</i>	<b>Normal pan and tilt control.</b>
	<i>PINV</i>	<i>ON</i>	Reverse DMX pan control, right → left.
		<i>OFF</i>	<b>Normal pan control, left → right.</b>
	<i>TINV</i>	<i>ON</i>	Reverse DMX tilt control, down → up.
		<i>OFF</i>	<b>Normal tilt control, up → down.</b>
<i>PTSP</i>		<i>NORM</i>	<b>Normal pan/tilt speed</b>
		<i>FAST</i>	Optimize pan/tilt movement for speed
		<i>SLOW</i>	Optimize pan/tilt movement for smoothness
<i>EFSP</i>		<i>NORM</i>	<b>Normal effects speed</b>
		<i>FAST</i>	Optimize effects movement for speed
		<i>SLOW</i>	Optimize effects movement for smoothness
		<i>PTSS</i>	Pan/tilt speed slave: effects speed copies the pan/tilt speed set via the control menu or via DMX
<i>STUD</i>		<i>OFF</i>	<b>Optimize effects for speed</b>
		<i>ON</i>	Optimize effects for silence (studio mode)
<i>PERS</i>	<i>DISP</i>	<i>ON</i>	<b>Display remains on</b>
		<i>2 MN</i>	Display extinguishes 2 minutes after last key press
		<i>10MN</i>	Display extinguishes 10 minutes after last key press
	<i>DINT</i>	<i>AUTO</i>	<b>Display adjusts automatically for ambient light level</b>
		<i>10-100</i>	Adjust display intensity manually
	<i>DLOF</i>	<i>ON</i>	Enable DMX lamp off
		<i>OFF</i>	<b>Disable DMX lamp off</b>
	<i>DRES</i>	<i>ON</i>	<b>Enable DMX reset</b>
		<i>OFF</i>	Disable DMX reset
		<i>5SEC</i>	Hold reset command for 5 seconds
	<i>ALON</i>	<i>OFF</i>	<b>No automatic lamp strike</b>
		<i>ON</i>	Lamp strikes automatically within 90 seconds of power on
		<i>DMX</i>	Lamp strikes if DMX is present, douses after 15 mins. without DMX
	<i>SCUT</i>	<i>ON</i>	<b>Gobo and color wheels turn shortest distance (across open)</b>
		<i>OFF</i>	Gobo and color wheels do not cross open
	<i>DICU</i>	<i>DIM1</i>	<b>Dimmer curve simulates tungsten performance</b>
		<i>DIM2</i>	Relatively linear dimmer curve
	<i>COLB</i>	<i>ON</i>	Enable color blackout
<i>OFF</i>		Disable color blackout	

Table 2: Control menu

Menu	Item	Options	Notes (Default settings in bold print)
DFSE	FACT	LOAD	Return all settings (not calibrations) to factory defaults
	CUS 1, CUS2, CUS3	LOAD	Load custom configuration
		SAVE	Save current configuration
INFO	TIME→HRS	TOTL	Total hours of operation since manufacture
		RSET	Hours of operation since counter reset (see page 13)
	TIME→L HR	TOTL	Total hours of operation with lamp on since manufacture
		RSET	Lamp hours since counter reset, see page 13
	TIME→L ST	TOTL	Total number of lamp strikes since fabricated
		RSET	Number of lamp strikes since counter reset, see page 13
	TEMP	HEAD	Head temperature
BASE		Base temperature	
VER	-	CPU firmware version	
DMXL	RATE	-	DMX transmission speed in packets per second
	QUAL	-	Percent of packets received
	STCO	-	Value of the DMX start code
	SHUT - EFSP	FINE	DMX value (from 0 - 255) received for each effect (LSB)
		COAR	DMX value (from 0 - 255) received for each effect (MSB)
MAN	RST	-	Reset fixture
	L ON	-	Lamp on
	LOFF	-	Lamp off
	SHUT	OPEN	Open shutter
		CLOS	Close shutter
		STRF	Fast strobe
		STRM	Medium strobe
		STRS	Slow strobe
	DIM	0-255	Dimmer
	COL 1	OPEN-RNDS	Color wheel 1: filters 1-8, continuous or random rotation
	COL 2	OPEN-RNDS	Color wheel 2: filters 1-8, continuous or random rotation
	GOB 1	OPEN	Gobo wheel 1 open
		G 1 I-G6 I	Rotating gobos 1 - 6 with indexed position
		G 1 R-G6 R	Rotating gobos 1 - 6 with continuous rotation
		G 1RS-G6RS	Rotating gobos 1 - 6 with rotation and shake
		CW F-CCWS	Gobo wheel 1 CW and CCW scroll; fast, medium, and slow
	GOB 2	OPEN	Gobo wheel 2 open
		G 1-G9	Static gobos 1 - 9
		G 1 S-G9 S	Static gobos 1 - 9 with shake
		CW F-CCWS	Gobo wheel 2 CW and CCW scroll; fast, medium, and slow
I/S	0-255	Rotating gobo index angle or rotation speed	

Table 2: Control menu

Menu	Item	Options	Notes (Default settings in bold print)
MAN cont.	ANIP	OPEN	Animation wheel open
		VPI	Vertical position (indexing)
		HPI	Horizontal position (indexing)
		VP R	Vertical position (rotation)
		HP R	Horizontal position (rotation)
		SPI 1	Scroll position 1 (indexing)
		SPI 2	Scroll position 2 (indexing)
		SPI 3	Scroll position 3 (indexing)
		SPI 4	Scroll position 4 (indexing)
		SPR 4	Rotation speed 4 (rotation)
		SPR 3	Rotation speed 3 (rotation)
		SPR 2	Rotation speed 2 (rotation)
		SPR 1	Rotation speed 1 (rotation)
	ANIR	0-255	Position (indexing) or speed (rotation)
	PRIS	ON	Prism in, no rotation
		OFF	Prism out
		CWF-CCWS	Prism in; fast, medium, slow rotation in both directions
	IRIS	0-C	Iris diameter: Press <b>Enter</b> , then use up and down arrows to select a value from 0 - 200
		CLSD	Iris closed
		PIOF	Fast opening pulse
		PIOS	Slow opening pulse
		PICF	Fast closing pulse
		PICS	Slow closing pulse
		RDOF	Fast random opening pulse
		RDOS	Slow random opening pulse
		RDCF	Fast random closing pulse
	RDCS	Slow random closing pulse	
FOC	0-255	Focus position	
ZOOM	0-255	Zoom position	
PAN	0-255	Pan position	
TILT	0-255	Tilt position	
TSEQ	-	RUN	Run a general test of all effects
UTIL (Press and hold Enter for a few seconds to use this menu)	FEBA	ON	Enable pan/tilt position correction system. See page 14.
		OFF	Disable pan/tilt feedback. Setting not saved.
	EFFB	ON	Enable position feedback from rotating effects. See page 14.
		OFF	Disable position feedback from rotating effects.
ADJ	--		See "Adjustment submenu" on page 37.

Table 2: Control menu

Menu	Item	Options	Notes (Default settings in bold print)
UTIL cont.	CAL	P <b>DF</b>	Pan calibration ( <b>DF</b> = offset)
		T <b>DF</b>	Tilt calibration
		D <b>DF</b>	Dimmer calibration
		C <b>1DF</b>	Color wheel 1 calibration
		C <b>2DF</b>	Color wheel 2 calibration
		G <b>1DF</b>	Gobo wheel 1 calibration
		G <b>2DF</b>	Gobo wheel 2 calibration
		F <b>0DF</b>	Focus calibration
		Z <b>0DF</b>	Zoom calibration
		I <b>RDF</b>	Iris calibration
		P <b>RDF</b>	Prism calibration
		D <b>FOF</b>	-
	U <b>PLD</b>	SURE	Manually set fixture to software update mode.

**Table 2: Control menu**

# ADJUSTMENT SUBMENU

The *UTIL*→*ADJ* menu is for use by service technicians when performing adjustments.

Menu	Item	Options	Notes
<i>RST</i>	-	-	Reset fixture
<i>L ON</i>	-	-	Strike lamp
<i>L OFF</i>	-	-	Douse lamp
<i>HEAD</i>	<i>DIM</i>	<i>TOOL</i>	For factory use
		<i>OPEN</i>	Dimmer and color 1 to open positions
		<i>ADJ</i>	Dimmer blades against stop, color 1 magnet aligned with sensor
		<i>CLOS</i>	Close dimmer
		<i>TEST</i>	Reset dimmer and color 1
	<i>EFE</i>	<i>TOOL</i>	For factory use.
		<i>OPEN</i>	Color 2, gobo 1 and 2, iris, and animation wheel to open
		<i>ADJ</i>	Color 2, gobo 1 and 2, and animation wheel magnets aligned with sensors
		<i>TEST</i>	Reset effects in gobo/color/iris/animation module.
	<i>ZFP</i>	<i>TOOL</i>	For factory use
		<i>ADJ</i>	Prism, zoom, and focus to adjustment positions
		<i>IN</i>	Prism in
		<i>OUT</i>	Prism out
		<i>TEST</i>	Reset zoom, focus, and prism
	<i>PATI</i>	-	<i>NEUT</i>
<i>PNTD</i>			Pan neutral, tilt down
<i>PNTU</i>			Pan neutral, tilt up
<i>PLTN</i>			Pan left, tilt neutral
<i>PRTN</i>			Pan right, tilt neutral
<i>PLTD</i>			Pan left, tilt down
<i>PRTU</i>			Pan right, tilt up

**Table 3: Adjustment menu**

# CONTROL MENU SHORTCUTS

The following shortcuts are available in the MAC 550 Profile control panel from software version 2.0:

<b>Shortcut</b>	<b>Function</b>
Hold [Menu] and press [Up]	Resets fixture
Hold [Enter] and press [Up]	Strikes lamp
Hold [Enter] and press [Down]	Douses lamp
Hold [Menu] and [Enter] while applying power	Freezes pan and tilt

# DISPLAY MESSAGES

Message	Appears when...	What to do
<i>RST</i> (Reset)	... the fixture is indexing effects at startup.	Wait for reset to complete.
<i>SRST</i> (Serial reset)	... the fixture has received a reset command from the controller.	Wait for reset to complete. Set <i>PERS</i> → <i>DRRES</i> to <i>OFF</i> to prevent accidental reset commands.
<i>HOME</i>	... the effects have been indexed and are moving to their default positions.	Wait a few moments.
<i>DOOR</i>	...the lamp access cover is not fully closed.	Verify that the lamp access cover is locked in place.
<i>LERR</i> (Lamp error)	... the lamp does not ignite within 30 seconds of receiving the 'Lamp ON' command. Likely reasons are a missing or defective lamp, or insufficient AC voltage.	Check the lamp. Check that the voltage and frequency settings match the local supply.
<i>SHER</i> (Short error)	... the fixture detects the lamp is ON but no 'Lamp ON' command has been received. This can occur if the lamp relay is stuck or if the lamp-power feedback circuit fails. The fixture may be operated but remote lamp on/off may be affected.	Contact Martin service personnel for assistance.
<i>BTER</i> (Base temperature error) <i>HTER</i> (Head temperature error) <i>LTER</i> (Lamp temperature error)	... there is a fault with the base, head or lamp temperature sensor respectively.	Contact Martin service personnel for assistance.
<i>LTCO</i> (Lamp temperature cut-out)	... the lamp temperature is too high and thermal protection circuits cut power to the lamp.	Allow fixture to cool. Ensure nothing is obstructing airflow around fixture. Clean air vents, air filters and fans. Reduce ambient temperature. If problem persists, contact Martin service personnel for assistance.
<i>DRER</i> (Driver current error)	... there is a driver/motor malfunction.	Contact Martin service personnel for assistance.
<i>DPER</i> (Display programming error)	... newly uploaded fixture software also requires updated display software.	Contact Martin service personnel for assistance.
<i>FDEP</i> (Feedback error pan) <i>FDET</i> (Feedback error tilt) <i>FDER</i> (Feedback error pan/tilt)	...pan ( <i>FDEP</i> ), tilt ( <i>FDET</i> ) or both ( <i>FDER</i> ) feedback circuits are malfunctioning. It will still be possible to operate the fixture, but it switches into a "safe" mode where maximum speed is reduced, thus preventing the fixture from losing track of its home position (losing step).	Contact Martin service personnel for assistance.
<i>PAER</i> (Pan time-out) <i>TIER</i> (Tilt time-out) <i>FOER</i> (Focus time-out) <i>ZOER</i> (Zoom time-out)	...the electric indexing circuit is malfunctioning. The fixture will, after the time-out, establish a mechanical stop, and continue to work normally.	Reset fixture again. Contact Martin service personnel if problem continues.
<i>C1ER</i> (Color wheel 1 time-out) <i>C2ER</i> (Color wheel 2 time-out) <i>G1ER</i> (Gobo wheel 1 time-out) <i>RGER</i> (Rotating gobo wheel time-out) <i>G2ER</i> (Gobo wheel 2 time-out) <i>APER</i> (Animation wheel position time-out) <i>ARER</i> (Animation wheel rotation time-out)	...the magnetic-indexing circuit malfunctions (e.g. sensor defective or magnet missing). After the time-out, the effect in question stops in a random position.	Reset fixture again. Contact Martin service personnel if problem continues.

Table 4: Display messages

# TROUBLESHOOTING

Problem	Probable cause(s)	Remedy
One or more of the fixtures is completely dead.	No power to fixture.	Check that power is switched on and cables are plugged in.
	Primary fuse blown (located near power inlet).	Disconnect fixture and replace fuse.
	Secondary fuse(s) blown (located on PCBs in base).	Disconnect fixture. Check fuses and replace.
Fixtures reset correctly but respond erratically or not at all to the controller.	Bad data link.	Inspect connections and cables. Correct poor connections. Repair or replace damaged cables.
	Data link not terminated.	Insert termination plug in output jack of the last fixture on the link.
	Incorrect addressing of the fixtures.	Check fixture address and protocol settings.
	One of the fixtures is defective and disturbs data transmission on the link.	Bypass one fixture at a time until normal operation is regained: unplug the XLR in and out connectors and connect them directly together. Have the fixture serviced by a qualified technician.
	XLR pin-out on fixtures does not match (pins 2 and 3 reversed).	Install a phase-reversing cable between the fixtures or swap pins 2 and 3 in the fixture that behaves erratically.
Time out error after fixture reset.	Effect requires mechanical adjustment.	Disable effects feedback (page 14). Contact Martin technician for service.
Mechanical effect loses position.	Mechanical train requires cleaning, adjustment, or lubrication.	Contact Martin technician for service.
No light and <b>LERR</b> error message displayed.	Lamp blown	Disconnect fixture and replace lamp.
	Lamp not installed	Disconnect fixture and install lamp.
	Lamp access safety switch open	Verify that lamp access plate is fully seated and locked in place.
Lamp cuts out intermittently.	Fixture is too hot.	Allow fixture to cool. Ensure nothing is obstructing airflow around fixture. Clean air vents, air filters and cooling fans. Reduce ambient temperature.

**Table 5: Troubleshooting**

# CIRCUIT BOARD CONNECTIONS

S1	Ballast FB
S2	Ballast FB
S3	Pan
S4	Tilt
S5	Gobo 1
S6	Rot.
S7	Zoom Sw.
S8	Focus Sw.
S9	
S10	
S11	Ani. Pos
S12	Ani. Rot.
S13	Gobo 2
S14	
S15	Color 1
S16	Color 2

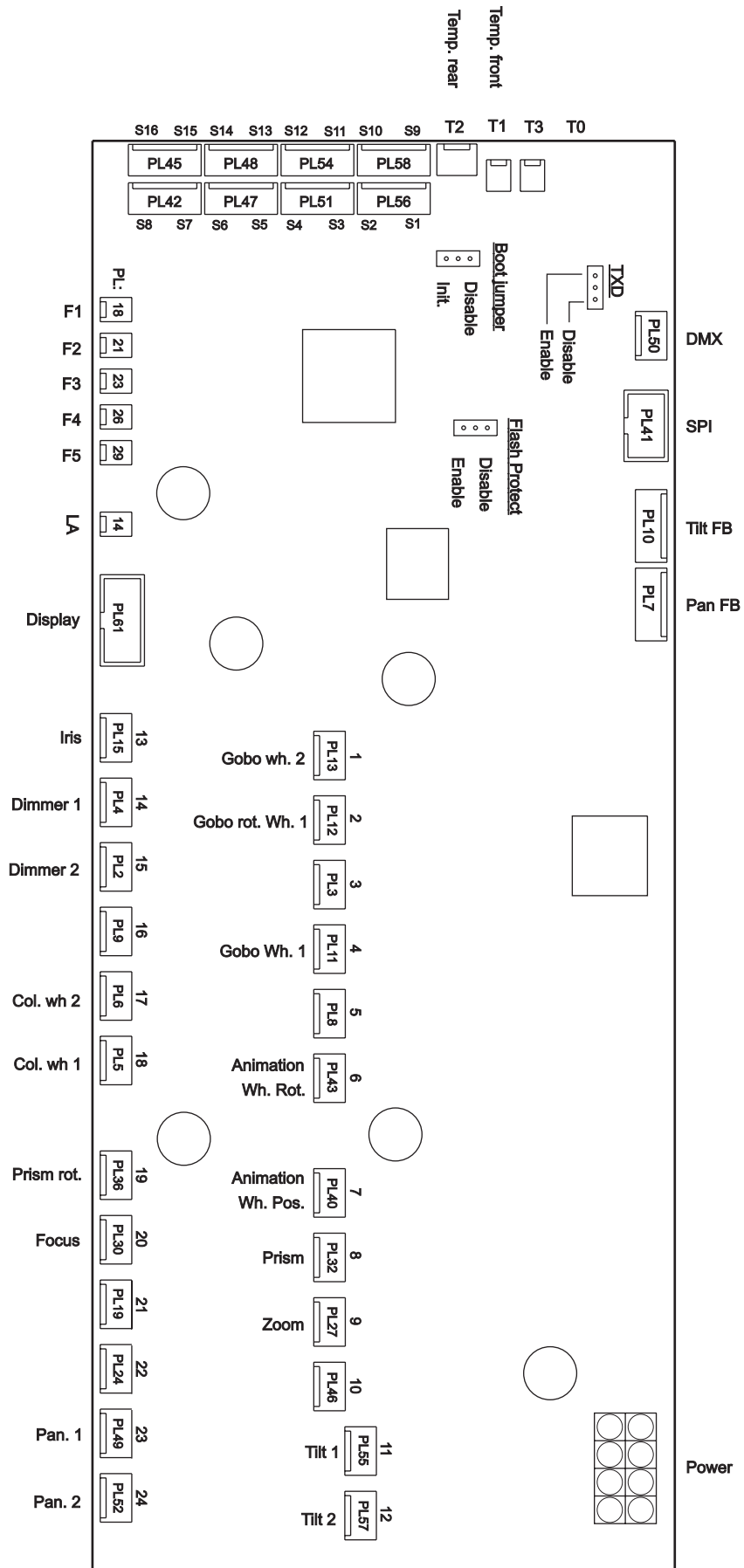

# MAC 550 PROFILE SPECIFICATIONS

## PHYSICAL

Length	450 mm (17.7 in)
Width	365 mm (14.4 in)
Height	636 mm (25.0 in)
Weight	31 kg (68 lbs)

## LAMP

Type	.400 W short-arc discharge
Lamp socket	Double-ended SFC 10-4 with key
Approved models	Osram HTI 400 W/D3 Philips MSR 400 SA/DE Gold
Ballast	Electronic 'flicker-free'

## DYNAMIC EFFECTS

Lamp power	On/off, hot restrike
Dimmer/shutter	Full-range dimming and variable speed flash, 8- or 16-bit control
Colors	Two 8-position wheels, 8- or 16-bit control
Rotating gobos	6 positions with continuous and indexed rotation, 16-bit control
Static gobos	9 positions, 8-bit control
Gobo animation	Variable rotation angle, indexed and continuous rotation, 8- or 16-bit control
Iris	ca. 2.5 mm - > 25 mm, 8- or 16-bit control
Focus	2 m (6.5 ft.) - infinity, 8- or 16-bit control
Zoom	14° - 30°, 8- or 16-bit control
Pan	540°, 16-bit control
Tilt	246°, 16-bit control

## CONTROL AND PROGRAMMING

Protocol	USITT DMX-512 (1990)
Control channels	21 or 27
Setting and addressing	Control panel with LED display, remote w/ MP-2 uploader
Movement control	Tracking and vector
Receiver	Opto-isolated RS-485
Software installation	Serial upload (MUF)

## PHOTOMETRICS

Light output	9300 lumens
Beam angle (focused on open gobo)	14° - 30°
Focal length	46 - 100 mm
Measurement source	Osram HTI 400 W/D3

## GOBOS

Outside diameter	27.9 +0/-0.3 mm
Maximum image diameter	23 mm
Maximum thickness	1.1 mm in static slots, 4 mm in rotating slots
Recommended glass	High-temperature Borofloat or better with dichroic or enhanced aluminum coating
Recommended metal	0.5 mm aluminum

## GOBO ANIMATION WHEELS

Outside diameter	116 mm +0/-0.25 mm
Image outer diameter	112 mm
Image inner diameter	32 mm
Construction	0.5 mm aluminum with magnet

## CONSTRUCTION

Housing	UV-resistant fiber-reinforced composite
Colors	black
Protection factor	IP 20

**INSTALLATION**

Mounting points ..... 2 pairs of 1/4-turn locks, offset 90°  
Orientation ..... Any

**THERMAL**

Maximum ambient temperature (T<sub>a</sub>) ..... 40° C (104° F)  
Maximum surface temperature ..... 160° C (320° F)  
Total heat dissipation (calculated) ..... 2200 BTU/hr

**ELECTRICAL**

Operating ranges ..... 100-120/200-240 VAC nominal, 50/60 Hz  
Power supply ..... Semi auto-ranging electronic switch-mode  
Main fuse for 200 - 240 V power ..... T 6.3 A  
Main fuse for 100 - 120 V power ..... T 10 A

**CONNECTIONS**

AC input ..... 3 m cable tail w/o power plug  
Data in/out ..... Locking 3-pin & 5-pin XLR, pin 1 shield, pin 2 cold (-), pin 3 hot (+)



**TYPICAL POWER AND CURRENT\***

@ 100 V, 50 Hz ..... 650 W, 6.8 A, PF 0.954  
@ 100 V, 60 Hz ..... 640 W, 6.7 A, PF 0.961  
@ 120 V, 60 Hz ..... 630 W, 5.5 A, PF 0.956  
@ 208 V, 60 Hz ..... 595 W, 3.1 A, PF 0.936  
@ 230 V, 50 Hz ..... 595 W, 2.8 A, PF 0.927  
@ 240 V, 50 Hz ..... 595 W, 2.7 A, PF 0.923

*V = Volts, Hz = Hertz, W = Watts, A = Amps, PF = power factor*

*\*Figures are typical, not maximum. Allow for a deviation of +/- 10%.*

**APPROVALS**

  EU EMC ..... EN 50 081-1, EN 50 082-1  
EU safety ..... EN 60598-1, EN 60598-2-17  
Canadian safety ..... CSA C22.2 No. 166  
US safety ..... ANSI/UL 1573

**INCLUDED ITEMS**

Lamp ..... Osram HTI 400/D3 (installed)  
Fuse for use with 200-240 V power ..... T 6.3 A (installed)  
Fuse for use with 100-120 V power ..... T 10 A  
Clamp attachment brackets ..... 2 quarter-turn Omega  
Gobo animation wheel ..... Radial breakup (installed)  
Color filters ..... 16 (installed)  
Gobos ..... 13 aluminum, 2 glass (installed)

**ACCESSORIES**

Spiral breakup animation wheel ..... P/N 62325049  
Linear breakup animation wheel ..... P/N 62325050  
Coarse tangential animation wheel ..... P/N 62325051  
Half-coupler clamp ..... P/N 91602005  
G-clamp ..... P/N 91602003  
MP-2 Uploader ..... P/N 90758420  
MAC 500-size stock gobos ..... See <http://www.martin.com>

**ORDERING INFORMATION**

MAC 550 Profile in cardboard packing case ..... P/N 90217000  
MAC 550 Profile in flight case ..... P/N 90217010

## Notes

## Notes

## Notes



