

SKYWINDER INSTRUCTION MANUAL

Introduction

SKYWINDER is a vertical access aerial work platform, which is operated by a single person. Manufactured from lightweight aluminium extrusions, the SKYWINDER elevates by climbing up a central mast section, using a rack and pinion. The operator simply rotates the levers on the winch mechanism and ascends.

The mast is supplied in various lengths, dependant upon model and is extended by locking intermediate sections together to achieve the desired height.

All models are supplied with outriggers and jacking legs to cater for uneven ground.

The SKYWINDER is fitted with non-marking rubber wheels for mobility once assembled. Dis-assembled, the apparatus is easily transported and handled in its knock-down form, which enables it to fit into small areas.

Essential Safety Instructions

The SKYWINDER is a simple, uncomplicated machine. However, by nature of its intended working environment, utmost care should be exercised at all times.

Operators are reminded that the SKYWINDER is a personal aerial work platform and ***should not*** be used as a material hoist or crane.

Operators should not over-stretch whilst operating or working from the platform. Never use additional equipment, i.e. ladders or boxes to obtain increased height. Under no circumstances should additional mast extensions be used in excess of the permissible four intermediate mast sections and one top mast. Ensure that all the materials and equipment are safely stored within the confines of the basket.

Never attempt to leave the basket during operation.

Always be aware of people below and their relationship with the exclusion zone.

Operators should be conscious of the safe working load, which should at all cost, be strictly adhered to.

Operators are required to monitor the weather during operation.

Never affix or carry materials which would intensify the wind loading.

Always ensure that the outriggers are in use and that levelling jacks have taken consideration of gradients. Never operate on unfirm ground or in windy conditions exceeding a gentle breeze. Ensure that there are no protruding objects in the line of the travelling platform and that distances to adjacent buildings are kept to a safe margin.

Never attempt to have the apparatus moved whilst in operation and ensure that outriggers and levelling jacks are used throughout the operation of the unit. Only move the apparatus with the platform in its grounded rest position.

Never move the platform on uneven ground or in windy conditions with the mast sections still in place. Whilst moving the platform, ensure there are no ground or aerial obstructions.

Ensure none of the components are damaged. Never use a component that is anyway suspected of being damaged.

Before erecting and during elevation of the apparatus, ensure that there are no forms of electrical hazards present, *pay specific attention to overhead power lines.*

Clearly define an exclusion zone around the apparatus with the appropriate signage and warning devices, to ensure that persons on the ground are aware of your aerial activities.

Transport and Handling

The SKYWINDER has been designed to be lightweight and compact. However, when handling, always make sure that adequate protection is afforded when lifting and moving the product.

Every possible care has been taken to reduce sharp components and heavy objects. Always summon assistance; never struggle to assemble the apparatus single handed.

Always ensure that during transportation, all loose objects are securely locked and that risk of projectiles is removed.

Assembly Detail

Unpack SKYWINDER and identify that all components illustrated in *figure 1* are present. Ensure that all components appear undamaged.

Having familiarised yourself with the major items of SKYWINDER, carefully undertake the assembly, following these instructions.

(For SK1C-SK5C Models Only) To construct the main chassis rail, attach front leg section by offering leg over connecting stub, ensuring that the collar fits flush with the back of the mast and tighten down bolt A, using full hand pressure. (See *Figure 2*).

Use the viewing hole to make sure that the chassis members have butted tightly together, if not undo bolt A and relocate leg correctly.

Having positioned the apparatus in the desired working position, swing out both side legs "A" until the hinged braces A3 are straight.

Figure 1

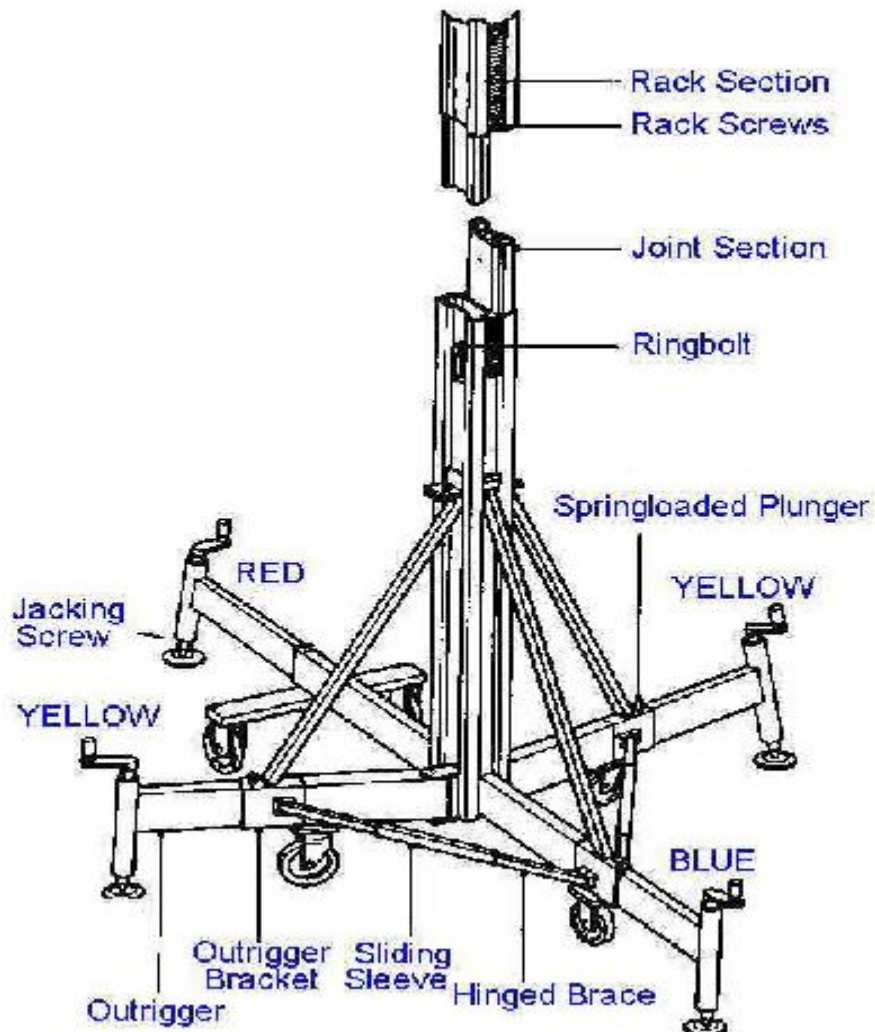

Figure 2

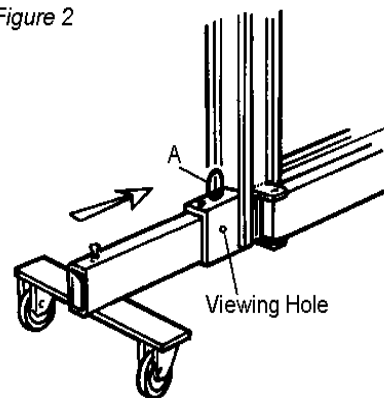

Figure 3

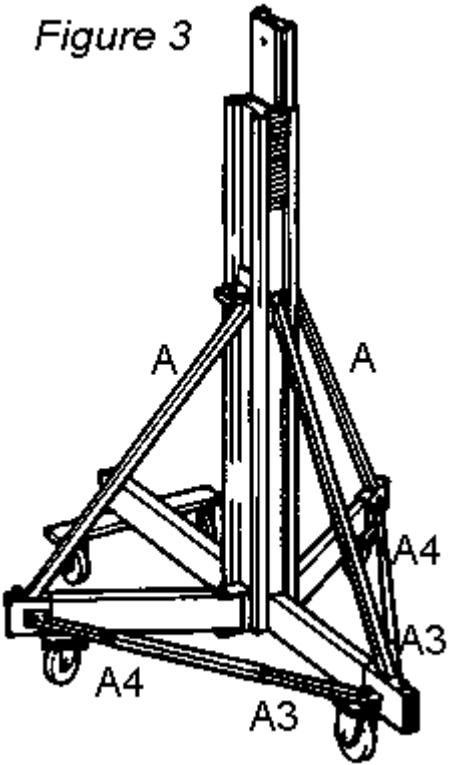
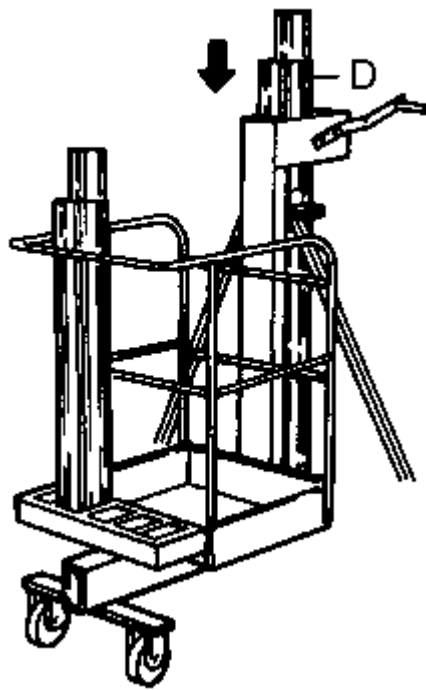

Figure 4



Lock each brace by moving sliding sleeve A4 to central position as shown in Figure 3. Fit work platform by offering basket assembly over fixed mast "D". Make sure nylon rollers and pinion gear engage centrally on the mast.

Lower platform onto base, using lowering handles. (Figure 4)

Insert outriggers onto appropriate legs on the chassis. Each outrigger is colour coded to identify its length and relative position on the SKYWINDER assembly. On no account should these positions be changed in any way.

When fitting outriggers, make sure that the longest outrigger **RED** is

fitted to the platform side and the shortest outrigger **BLUE** opposite to it. The other two outriggers **YELLOW** are fitted to each side.

Fit each outrigger in turn. When located in their correct positions, the spring loaded plungers lock with an audible "click".

When the SKYWINDER is positioned against a wall, the longest outrigger should be pushed fully into the fixed member. (Figure 6a).

Figure 6a

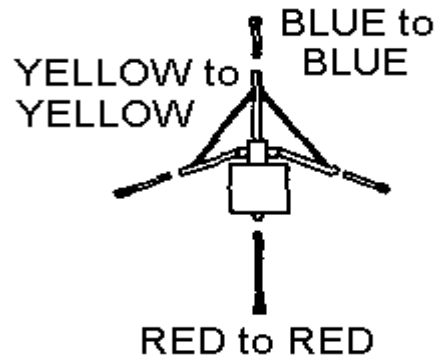

Under normal working positions outriggers should be fully extended. This position is indicated when the figure "5" marked on the top of the outrigger is visible and the spring plunger is locked. However when working in confined spaces, the outriggers can be moved to an in-board position, ensuring that the visible index numbers marked on the top of the outriggers, equal or exceed the quantity of mast sections being used. (See Figure

Figure 5

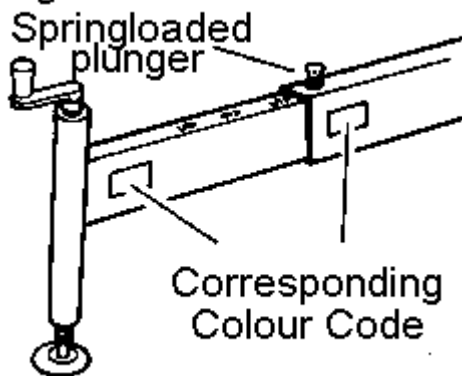

Figure 6b

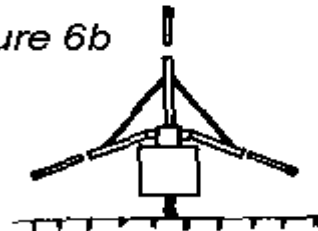
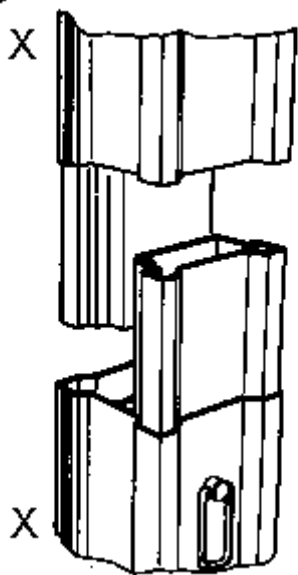

Figure 7



Before winding down the levelling jacks, ensure that the ground is firm and capable of supporting the SKYWINDER.

Wind down adjustable jacking screws until each wheel is lifted clear of the ground. Further fine adjustment is essential, using the spirit level mounted on the chassis, to ensure the SKYWINDER is level and the mast is subsequently vertical.

Once the chassis has been levelled, the intermediate mast sections can be stored within the basket in the prepared section at the rear.

The mast section and each extension piece has a distinctively keyline running down its length X-X to the operator's left (standing in work platform).

As each extension piece is added, these keylines must line-up on the same side.

The length of the interlocking joint sections has a difference of 15mm, so that the top section will always be entered first when assembling. When both sections are engaged the two mast sections should sit flush along the joint line, if not, slacken ringbolts slightly and adjust. Tighten ringbolts on either side of the joint, using full hand pressure until joint is rigidly held. Line up ringbolt handlebars lengthways to mast and fold flat in recess to clear hoist side plates.

Always ensure that a top mast incorporating rack stop block and no extension spigot is fitted last, regardless of the number of mast sections being used.

Clearly define an exclusion zone around the apparatus with appropriate signage and warning devices, to ensure that persons on the ground are aware of your aerial activities.

The SKYWINDER is now ready to use. **To Ascend**, rotate the operating levers toward you. Winding should be done with an even, steady action, using BOTH hands. Up to FIVE additional mast sections can be carried on the rear of the work platform, supported in the carrier provided. These mast sections can be added as required to reach desired working height, following instructions given earlier. Always make sure that you are never over-stretching when adding on mast sections and that you are in complete control of the weight at all times.

Once the desired height is reached, engage the mechanical lock/safety brake to immobilise the descent mode.

The lock is engaged by rotating the levers until the right hand lever is horizontal with the handle nearest the operator. The centrifugal weight can now be located on its stop by pulling it towards the basket.

To disengage, raise the platform as previously described and the weight springs back to its rest position.

The same operation should be used if the lock has been activated in its fail safe mode
(See Figure 8).

Figure 8

Winding down MUST be done with LEFT HAND only, rotating levers away from the operator, removing mast sections in turn, until lowering is complete.

Operation with both hands will release the pressure on the braking system and will result in the over-acceleration of the carrier and subsequent activation of the safety brake.

To dismantle SKYWINDER, follow the assembly instruction in reverse, ensuring reasonable care is taken when handling the heavier and sharper objects.

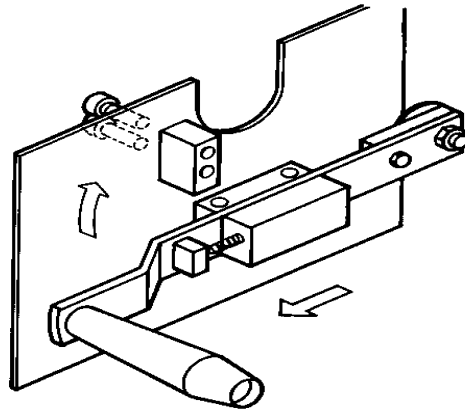
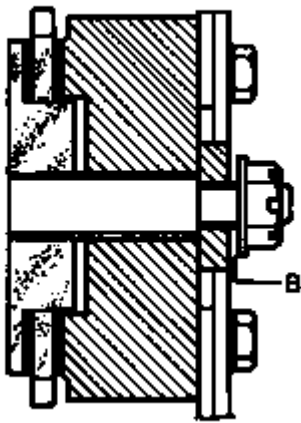

Figure 9



Maintenance

Adjustment of Friction Discs

A normal clearance of approximately 1mm should be allowed at "B" when friction nut is tightened against friction discs. Clearance at "B" should be periodically checked for excessive wear and adjusted accordingly by removing split pin and tightening castle nut one flat.

Replacement of Friction Discs

If after a long period of usage, the friction discs become worn or can easily be replaced as follows:

damaged, they

1. Remove nut from
2. Unscrew
3. Remove four bolts
4. Remove discs (See

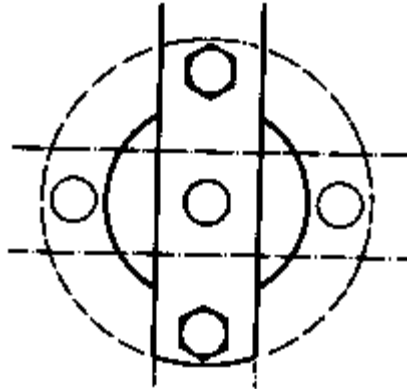

split pin and unscrew castle pinion shaft friction nut and remove ratchet cover by unscrewing

ratchet wheel and 2 brake (Figure 12).

IMPORTANT

Figure 10



When re-assembling ratchet wheel, make sure that the face of the ratchet wheel tooth engages with the longer arm of the pawl, which must point towards the work platforms as shown in *Figure 10*.

Re-assemble in reverse order to above, making sure that the friction nut is very free on the pinion shaft. If not, clean thoroughly and apply a light smear of grease on the pinion shaft screw. Set the nominal 1mm friction disc clearance as shown in *Figure 9* and fit split pin. Position and re-fit brake handle as shown in *Figure 11*.

Positioning Brake Handle

Friction disc maintenance may alter the position of the brake handle relative to the fixed handle. The brake handle can be re-positioned on the friction nut by fitting to the alternative pair of fixing holes.

Daily Checks

Prior to operating SKYWINDER, always examine the structure and components to identify any damage which may have occurred since its previous use.

Ensure that the winding mechanism works and that it is capable of supporting its load.

Always activate the centrifugal safety brake by sliding it along its axis; lubricate as necessary, to allow unimpeded travel.

Check the condition of the rack and pinion, ensuring that all teeth are present and not damaged.

Make sure that the levelling jacks are sound and capable of holding the load by assembling the apparatus and then applying pressure to each jack in turn.

Consult the manufacturer should you suspect any damage and do not use SKYWINDER until a detailed inspection has been carried out.

Never attempt to modify your SKYWINDER without prior consultation with the manufacturer.

Cleaning and Lubrication

Clean all parts of the SKYWINDER, except the operating handles, with a light oil or silicone spray. *Never wash with water or detergents.*

Make sure that during cleaning, the friction disc material inside the winch is not contaminated.

Mast bolts should be lightly greased.

Servicing

After a period of 12 months, based on daily usage, the SKYWINDER should be serviced by the manufacturer, at which point the structure and all components can be examined in detail.

Winch Mechanism Ratchet

In the unlikely event of failure of any part of the winch mechanism under operating conditions, the winding ratchet is protected by a fail-safe pawl, which locks automatically. The function of the pawl is indicated by a distant "clicking" sound when the work platform is being hoisted. If this sound is not heard, examine the pawl and spring immediately, with work platform at ground level.

Figure 12 - Winch

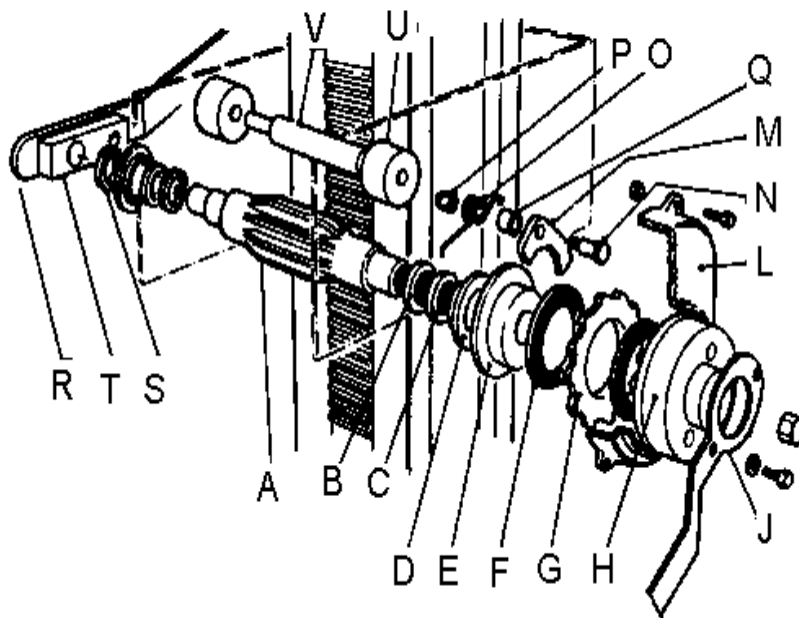

Item	Description	Quantity
A	Pinion Shaft	1
B	Spacing Washer	2
C	Bearing	2
D	Bearing Housing	2
E	Reaction Plate	1
F	Friction Disc	2
G	Ratchet Wheel	1
H	Friction Screw Nut	1
J	L/H Handle	1
L	Cover	1
M	Pawl	1
N	Pawl Spindle	1
O	Pawl Spring	1
P	Spindle Locknut	1
Q	Spindle Sleeve	1
R	R/H Handle	2
S	Handle Spacing Sleeve	1
T	Handle Adaptor	1
U	Nylon Roller	2
V	Spindle	1